

**Wide Input Voltage DC/DC Converters Application Guide 2017**

<b>I. Selection Guide.....</b>	<b>3</b>
A. Selecting Power Supply.....	3
B. Designing Power Distribution System.....	5
<b>II. DC/DC Converter Testing Suggestions.....</b>	<b>8</b>
A. Testing the Circuit Itself.....	8
B. Testing Converter's Performance.....	9
<b>III. Applications of DC/DC Converters.....</b>	<b>17</b>
A. DC/DC Converters Connected in Series.....	17
B. DC/DC Converters Connected in Parallel.....	18
C. Input Reverse Polarity Protection.....	20
D. Input Under-voltage Protection.....	20
E. Input Over-current and Over-voltage Protection.....	21
F. Input and Output Filtering Circuit.....	22
G. Electromagnetic Interference and Electromagnetic Compatibility.....	24
H. Capacitive Load.....	26
I. Pin-out.....	26
<b>IV. FAQs.....</b>	<b>30</b>
A. Do MORNSUN's DC/DC converters support hot-plug?.....	30
B. Can MORNSUN's DC/DC converters be used at no-load or light-load?.....	30
C. Reasons cause failures of MORNSUN's DC/DC converters?.....	30
D. High standby power consumption for converters over 20W?.....	31
E. Operating temperature?.....	31

---

F. Dual outputs, and load imbalance?.....	31
G. Power-down sequences for DC/DC Converters with multiple outputs?.....	31
H. Measures suppressing noise?.....	32

MORNSUN

## I. Selection Guide

### A. Selecting Power Supply

The first step is to confirm specifications of the power supply and then determine to choose a standard power supply or a customized one according to requested parameters.

#### First, confirm input voltage.

For 2:1 input voltage range of 5V (4.5-9V), 12V (9-18V), 24V (18-36V) and 48V (36-75V), DC/DC Converters WR series and VR series are recommended. For 4:1 input voltage range of 24V (9-36V), 48V (18-75V) and 110V (40-160V), DC/DC Converters UR series are recommended for applications which have a higher requirement for output voltage. These applications include but are not limited to industrial bus power supply (24V), communication bus power supply (48V), railway power supply (110V), transformer rectifier output (220V), all kinds batteries (lithium batteries, dry batteries, etc.) and long-distance transmission. For converters above 3W output power, to raise operation efficiency, it is recommended to select VR series or UR series.

#### Second, confirm output voltage.

Common output voltages are 3.3V, 5V, 9V, 12V, 15V, 24V,  $\pm 5V$ ,  $\pm 12V$ ,  $\pm 15V$ .

#### Third, confirm power.

Output current can be determined once the load is confirmed. The load current determines power and affects the converter's reliability and price. It's suggest to use the converter in 30%-80% of its power at ambient temperature. In high temperature or low temperature environment, derating should be taken into account. Choosing a right output current is one of the key factors in successful design. Inappropriate current will lead to lower reliability and high cost.

In the case of high temperature and poor heat dissipation condition the converter should be used at least 30%-40% derating and a larger one is better. Given the converter had to be used at high temperature of over 70°C for a long time, please contact our sales department for more information.

#### **Fourth, confirm isolation.**

Isolation makes input and output of the converter completely separate from each other (separate ground connection). It helps rise the loop's resistance in industrial bus system, isolates noise in analog circuit and digital circuit in hybrid circuit and converts voltages in multiple voltage power system, achieving safely isolation in harsh environments (lightning, arc interference). For converters with dual outputs, it should firstly confirm whether isolation is needed and then select a converter offering double isolation and dual outputs.

#### **Fifth, confirm package.**

It needs to take dimension, cost and the converter's reliability into account. Enough space should be reserved for the converter to reduce the interference to signal acquisition for its thermal radiation and the interference to other circuit components.

In short, it's best to select a standard package as far as possible, to meet lower cost, mature technology, less challenge of development and save development time.

For converters that have special requirements for high isolation, wide voltage range input, high temperature, EMC, UL certification and others, please contact our sales department.

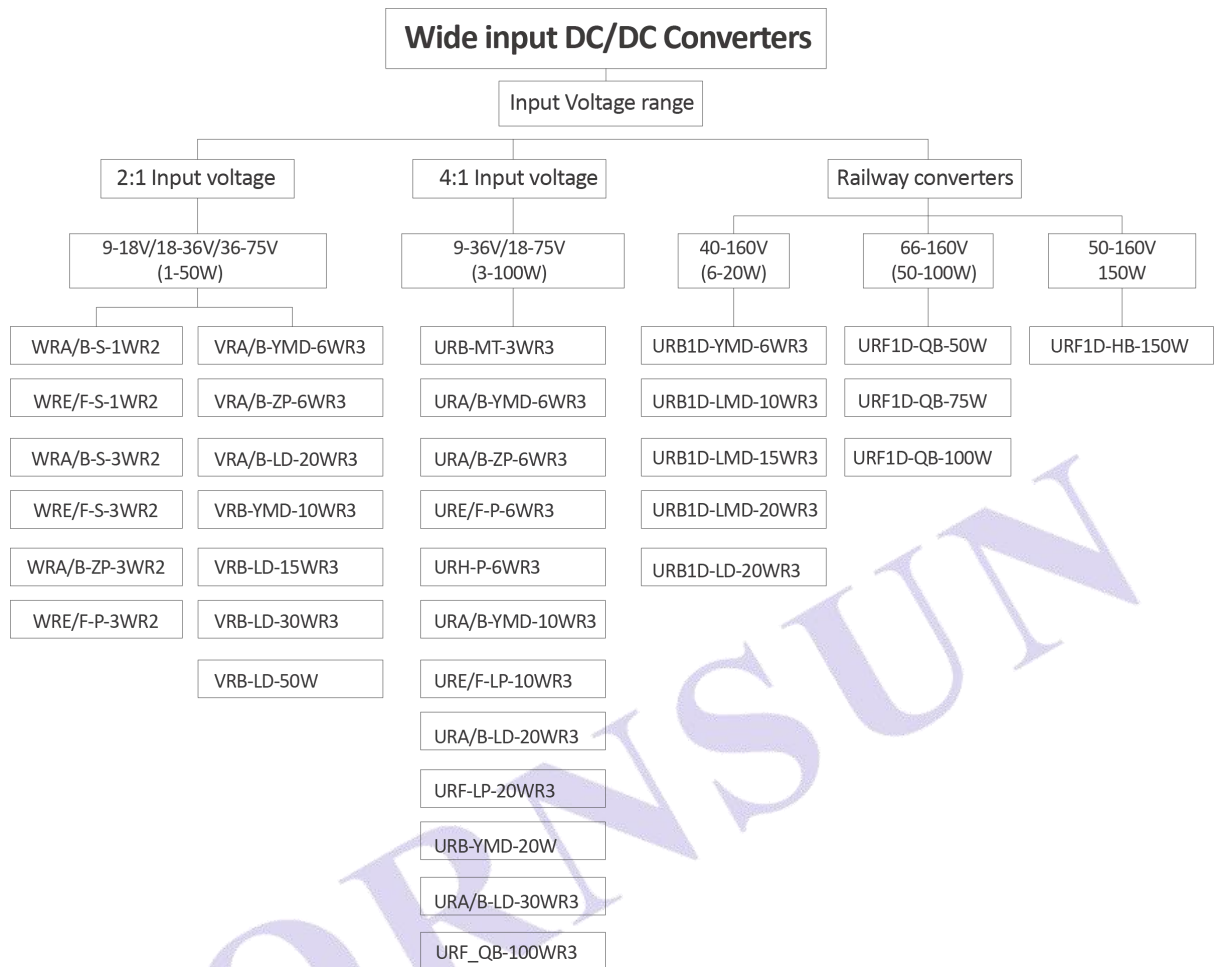

Diagram 1-1 Selection Block Diagram

Note: Nominal input voltage of WR series is 48V (36—72V).

## B. Designing Power Distribution System

Products' features and circuit's requirements should be taken into consideration when engineers design a power distribution system. And they have to optimize the system several times, by which acquires accurate operating parameters and environmental changes of practical circuits to precisely choose suitable converters.

### Step one, mind ambient factors.

Ambient factors include ambient temperature, transmission distance and so on.

Ambient temperature can affect converters and external components. Considering that the converters are used in high temperature, low temperature or high and low temperature cycle (such as: engine room and cabin), corresponding parameters may

change. Engineers should clearly know these changes and design correct circuit in this application. It should be noted here that the ambient temperature of power module refers to the internal temperature of device, not room temperature. The former is usually higher than the latter in that the device contains many heat generating components.

Table 1-1 Industry working temperature distribution

Industries	Working temperature
Commerce	0-70℃
Industry	-40-85℃
Vehicle on-board equipment	-40-105℃
Field exploration instrument	-55-85℃
Military	-55-125℃

It also should be noted that the module derates significantly at high temperature. In this case, the chosen converter should allow significant deration and connect an electrolytic capacitor with excellent high and low temperature. Please refer to datasheet when selecting the capacitor because at high temperature its withstand voltage significantly reduces, too.

Transmission distance is another factor affecting converters and external components. General suggestions are:

a) Non-isolation or low power converters are the first choices for indoors for its short distance, little temperature drop and weak interference.

b) Wide input and isolated, high-efficiency converters are the best choices for long-distance transmission. In addition to lightning protection, accurate transmission loss should be calculated.

c) It is recommended that start-up current of converter supplied by the power supply is 1.3 -1.6 times to ensure normal operation of the converter, resulting from long-distance transmission and large loss.

d) It is recommended to connect a capacitor at the input terminal of the converter to improve start-up performance itself.

Other ambient factors are interference caused by arc, electrostatic discharge, unstable AC, start-up switches, relays and lightning. As a result, input voltage and current may go far beyond the converter's tolerance and cause permanent damage to the converter and paralysis of the load circuit. In this case, there's no better choice to add protection circuit ensuring the safety.

### **Step two, mind working circumstance.**

A common sense is all converters lose certain power and change it into their own heat energy, which will make surrounding environment warmer. Further, it cause data interference (thermal sensor) and performance degradation of device and even cause short-circuit to fire. Thus, larger ventilation or heat dissipation space to reduce temperature rise is essential to ensure safety.

As DC/DC converters adopts switching technology, their own switching oscillator circuit and internal magnetic components will produce electromagnetic interference and pollution to surrounding ones by conduction and radiation (note: electromagnetic interference, shorting for EMI, refers to pollution from electromagnetic energy that affects environment by electromagnetic radiation and conduction). EMI cannot be completely eliminated, but can be reduced a safe level by certain measures for electromagnetic compatibility.

### **Step three, mind layout.**

Unreasonable grounding and layout easily tend to cause unstable system, high noise and other undesirable phenomena.

In many applications, analog circuit and digital circuit share the same power supply, in which it is very important to separately use them or completely isolate the power supply from ground loops. It aims to avoiding the interference from digital DC voltage drop variation and logic suppressor process to analog circuit system.

In high-speed/dynamic analog circuit or digital circuit, the distributed resistance and inductance become noticeable and easily cause noise spikes for rapid changes of load current when the wire is long. In this case, load decoupling and eliminating resonance are recommended which is caused by distributed parameter.

## II. DC/DC Converter Testing Suggestions

Product's performance in practical application is also vital except a right power supply. Therefore, it needs to be tested and verified before use. Common test methods are available as follows:

### A. Testing the Circuit Itself

Kelvin-style test method is a standard one as shown in diagram 2-1. Test conditions: ambient temperature  $T_a=25^\circ\text{C}$ , humidity <75%.

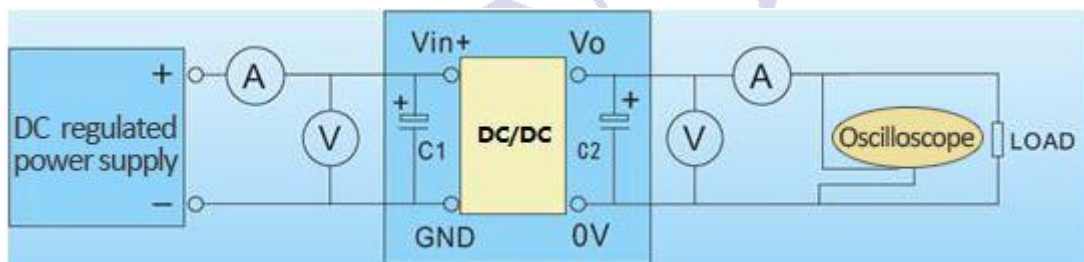

Diagram 2-1 Kelvin-style test method

Test instruments: DC adjustable regulated power supply (wide enough input voltage range), ammeter A (accuracy: 0.001A), voltmeter V (accuracy: 0.001V), load resistance (rated load:  $\frac{V_o^2}{P}$ , light load:  $\frac{V_o^2}{10\%*P}$ )

Notes:

a) Wire connection: the less wire loss, the better it is. A multi-strand copper wire with 1mm diameter is the best choice to avoid excessive voltage drop. When the load current is large, it should shorten distances between output pins and the load, and increase cross-sectional area of the connecting wire to reduce the excessive voltage drop.

b) Grounding: Improper grounding can cause unintended noise in the circuit. When



testing ripple and noise, it is suggested to test output by using contact measuring method with a single pole, in case causing measurement errors. Contact measuring method helps reduce external interference and the single pole does common ground of input and output. (See “ripple and noise”)

c) Load: To acquire accurate voltage and ripple under a correct current limiting point of front-circuit, output capacitive load should be within rated one at 10%-100% load.

d) For more details please refer to datasheet.

## B. Testing Converter’s Performance

Performance testing begins with correct connections of power modules, by which to confirm whether parameters meet requirements or not.

### a) Output voltage accuracy:

$V_{outnom}$ : output voltage at nominal input voltage and full load	Output voltage accuracy $= \frac{V_{out} - V_{outnom}}{V_{outnom}} \times 100\%$
$V_{out}$ : tested output voltage at nominal input voltage	

e.g. (WRB1212S-1WR2):  $V_{outnom}=12V$ , rated load= $144\Omega$ ,  $V_{out}=12.039V$ ,

$$\text{Output voltage accuracy} = \frac{12.039 - 12.000}{12.000} \times 100\% = 0.325\%$$

### b) Line regulation:

Wide input, regulated output series:

$V_{outnom}$ : output voltage at nominal input voltage and rated load	Line regulation $= \frac{V_{mdev} - V_{outnom}}{V_{outnom}} \times 100\%$
$V_{outh}$ : output voltage at rated load when input voltage at its upper limit	
$V_{outl}$ : output voltage at rated load when input voltage at its lower limit	

$V_{mdev}$  :  $V_{outh}$  or  $V_{outl}$  which is deviated from  $V_{outn}$  more

e.g. (WRB2405S-3WR2): rated load=600mA,  $V_{outh}$ =5.01V,  $V_{outl}$ =5.00V,  $V_{outnom}$ =5.01V,

$$\text{Line regulation} = \frac{5.00 - 5.01}{5.01} \times 100\% = -0.2\%$$

### c) Load regulation:

Wide input, regulated output series:

$V_{b1}$  : output voltage at nominal input voltage and 10% load

$V_{b2}$  : output voltage at nominal input voltage and 100% load

$V_{b0}$  : output voltage at nominal input voltage and 50% load

$V_b$  :  $V_{b1}$  or  $V_{b2}$  which is deviated from  $V_{b0}$  more

Load regulation

$$= \frac{V_b - V_{b0}}{V_{b0}} \times 100\%$$

### d) Cross adjustment rate

DC/DC converters offering dual-output or more usually take voltage from the output terminal of primary circuit to form a closed-loop control loop. The primary circuit's load current changes is not significant to its output voltage. However, auxiliary circuit's voltage is obtained through transformer coupling. Both the primary circuit's load current changes and the auxiliary circuit's will lead to great changes of the auxiliary circuit's output voltage. Therefore, the load of each output should be balanced not more than 5% for these DC/DC converters. Otherwise, the output voltage and load regulation rate will be beyond the accuracy range. It should draw more attention that the primary circuit cannot be use at no-load for DC/DC converters with multi-outputs.

$V_{1(50\%)}$  : output voltage at 50% primary circuit's load

$V_{2(50\%)}$  : output voltage at 50% auxiliary circuit's load

$V_{2(10\%)}$  : output voltage at 100% auxiliary circuit's load  
and 10% auxiliary circuit's load

Cross adjustment rate

$$= \frac{V_2' - V_{2(50\%)}}{V_{2(50\%)}} \times 100\%$$

$V_2(100\%)$  : output voltage at 10% auxiliary circuit's load  
and 100% auxiliary circuit's load

$V_2(50\%), V_2(10\%), V_2(100\%)$  : output voltage at same circuit

$V_2'$  :  $V_2(10\%)$  or  $V_2(100\%)$  which is deviated from  
 $V_2(50\%)$  more

### e) Efficiency:

$V_{in}$  : nominal input voltage

$I_{out}$  : output current at full load

$V_{out}$  : output voltage at full load

$I_{in}$  : input current

Efficiency

$$\eta = \frac{I_{out} \times V_{out}}{I_{in} \times V_{in}} \times 100\%$$

e.g. (WRB1212S-1WR2):  $V_{in}=12V, V_{out}=11.951V, I_{out}=83.6mA, I_{in}=100.7mA,$

$$\eta = \frac{0.0836 \times 11.951}{0.1007 \times 12.000} \times 100\% = 82.68\%$$

### f) Ripple and noise:

Ripple and noise is the periodic and random AC variation superimposed on DC output, which affects output accuracy and usually is calculated with peak-to-peak (mVP-P).

First, set oscilloscope bandwidth 20MHz to effectively prevent high-frequency noise.

Second, test with parallel cable measuring method, twisted-pair cable measuring method or contact measuring method.

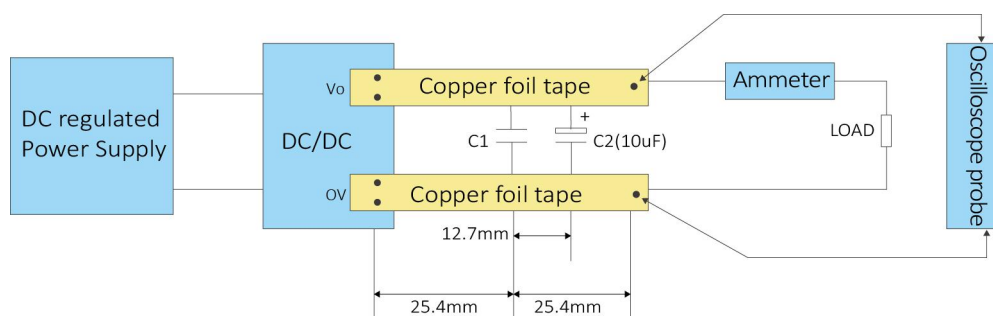

Diagram 2-2 Parallel cable measuring method

## Notes:

- C1: a high-frequency ceramic capacitor with 1uF capacitance.
- C2: an electrolytic capacitor with 10uF capacitance and twice withstand voltage higher than that of converters, suitable for wide input products (series prefixed with VR, WR and UR).
- Distance between two paralleled copper foils is 2.5 mm and, of which the sum of voltage drops should be less than 2% of nominal output voltage.

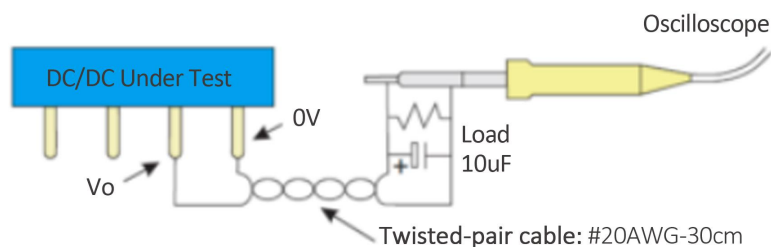

Diagram 2-3 Twisted-pair cable measuring method

Another is with twisted pair measuring method as shown above in diagram 2-3. Connect tested power supply  $V_o$  and 0V with a twisted pair which is composed of 30cm long and #20AWG, and then connect a dummy load between them. Next, connect a  $10\ \mu\text{F}$  electrolytic capacitor at the end of the twisted-pair cable, which connects the end of oscilloscope's probe at one terminal and connects the ground at the other.

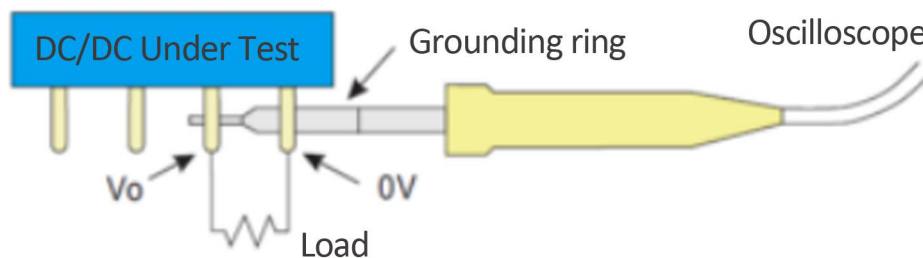

Diagram 2-4 Contact measuring method with oscilloscope

Contact measuring method, as shown in diagram 2-4, is usually adopted for oscilloscope to shield interference. Because the oscilloscope's ground clip could absorb various high-frequency noise, affecting test results. Whatever single output or double

outputs or more, the test method is similar. Connect oscilloscope probe to each output terminal. Then actual tested ripple and noise will vary depending on different circuit and external components. Diagram 2-5 shows the actual tested ripple and noise waveform.

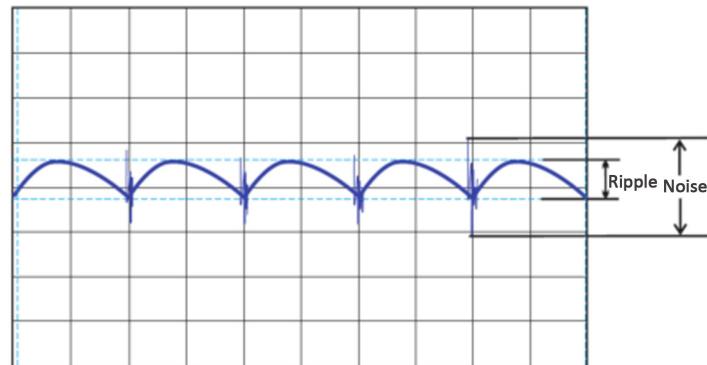

Diagram 2-5 Waveform of Ripple & Noise Test

#### g) Dynamic load:

When the load varies greatly, all the power supplies have a corresponding response time. During this time, the power supply's output voltage will produce instantaneous overshoot and then return to normal state. Dynamic response is an important indicator of power's performance and is measured by the overshoot and the response time.

The specific measurement method is to use an electronic load to carry out the power load's sudden change. Set the load current at 25% -50% -25% and 50% -75% -50% of the rated load. Next, set current's jumping and falling slope 0.08-0.1A / $\mu$ S. Last, measure the maximum deviation of the output voltage and response time with an oscilloscope. Waveform of dynamic load test is as shown in Diagram 2-6.

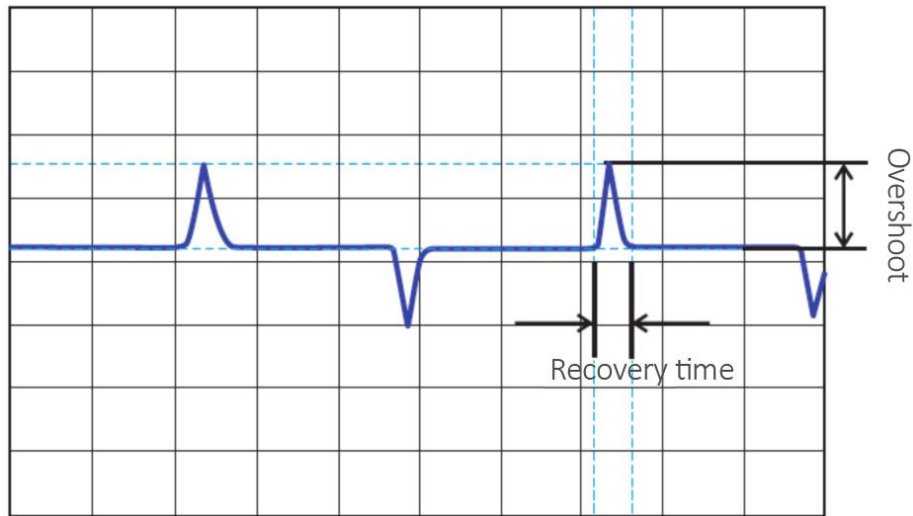

Diagram 2-6 Waveform of dynamic load Test

**h) Start-up time:**

Start-up time refers to corresponding delay time during which input voltage exists and output voltage reaches to a targeted value, which is usually tested at rated full load. In practical design, taking start-up time and ripple and noise into consideration together is recommended in that external filter including input or output capacitor will greatly delay the time. Fixed input DC/DC Converter adopts open-loop design, thus they have fast start-up time. For more details please refer to datasheet or contact our sales department. Diagram 2-7 shows the actual tested start-up time waveform.

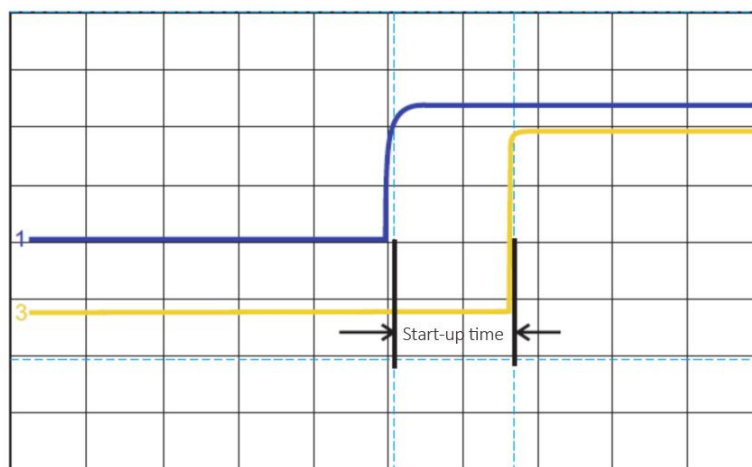

Diagram 2-7 Waveform of Start-up Time Test

i) Isolation and insulation:

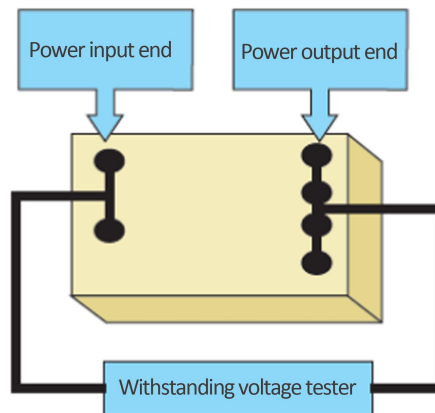

Diagram 2-8 Method of Withstand Test

Withstand test: Following withstand test standards, withstand value shall be set from 0 slowly upward and remain 1 minute at the maximum rated isolation.

Insulation test: measure it for 1 minute by applying isolation voltage between the input and output

Insulation resistance: the value should be above 1GOhm when applying 500VDC from input/output

Isolation voltage shown in datasheet is only valid for a one-minute quick test. Therefore, rated working voltage must refer to relevant standard if it's required longer operation at high withstand voltage. And the switching relationship between the isolation voltage and the rated working voltage, according to the IEC950 standard, is shown as Diagram 2-9. Standard typical breakdown voltage of IEC950 is shown in Table 2-1.

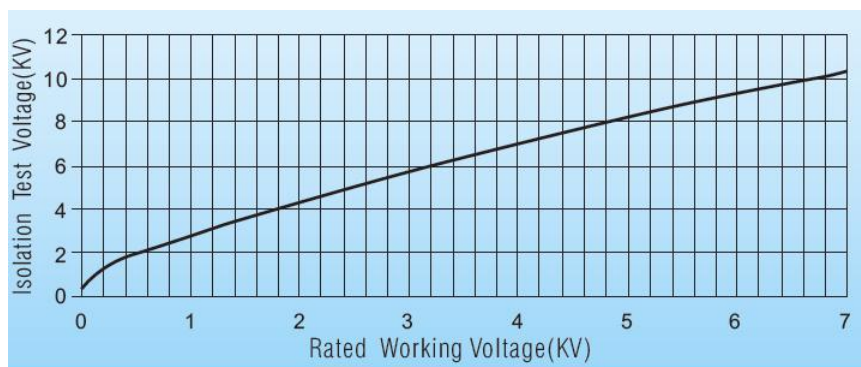

Diagram 2-9 Relationship between Isolation Test Voltage and Rated Working Voltage

Table 2-1 Typical Breakdown Voltage Ratings According to IEC950

Isolation Test Voltage (Vrms)	Rated Working Voltage (Vrms)
1000	130
1500	230
3000	1100
6000	3050

**j) Temperature rise test:**

Temperature rise test is usually with the help of thermal imager or thermocouple. The former can be affected and lead to a certain deviation in measurement results due to the emissivity. Therefore, the latter, test with thermocouple, is recommended.

For example, given that the ambient temperature  $T_a$  is  $25^\circ\text{C}$ , and the measured temperature of power supply  $T_c$  is  $60^\circ\text{C}$ . Then the temperature rise  $\Delta T$  is  $35^\circ\text{C}$  ( $\Delta T = T_c - T_a = 60^\circ\text{C} - 25^\circ\text{C} = 35^\circ\text{C}$ ).

Test: power supply is in nominal voltage input and at rated power.

Note: Temperature of power supply varies due to different power, material of case and internal design, etc. Under the same condition, a metal case has better heat dissipation, lower temperature of internal component and higher reliability than a plastic one. Therefore, it's recommended, in a closed environment, to keep away power supply from components that sensitive to temperature or isolate them for no natural ventilation.

**m) Input Reflection Ripple Current Test:**

The input reflection ripple current mainly refers to the periodic and random AC variation superimposed on DC output which is reflected by the converter. It needs an inductor and capacitor elements connected at its front-end to match the source impedance, as shown in Diagram 2-9. Inductance capacitance recommended values:  $L_{in}$  ( $4.7 \mu\text{H}$ ),  $C_{in}$  ( $220 \mu\text{F}$ ,  $\text{ESR} < 1.0 \Omega$  at  $100 \text{KHz}$ ).



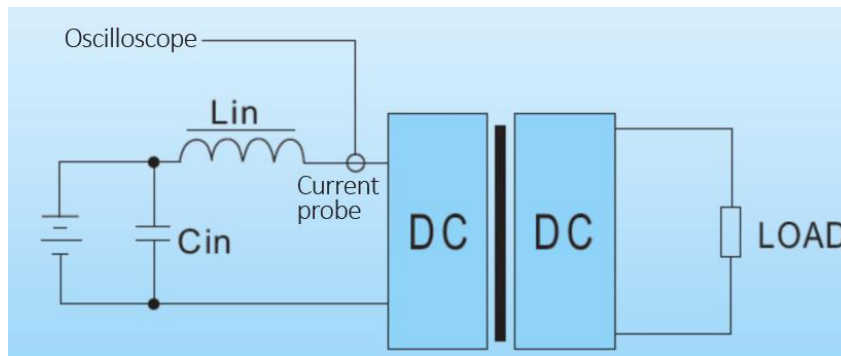

Diagram 2-10 Input Reflection Ripple Current Test

### III. Applications of DC/DC Converters

#### A. DC/DC Converters Connected in Series

DC output isolation module allows multiple modules in series. "Positive output" of one DC/DC Converter connects with "negative output" of the other DC/DC Converter one by one, as shown in Diagram 3-1, which results in certain unconventional or higher voltage values.

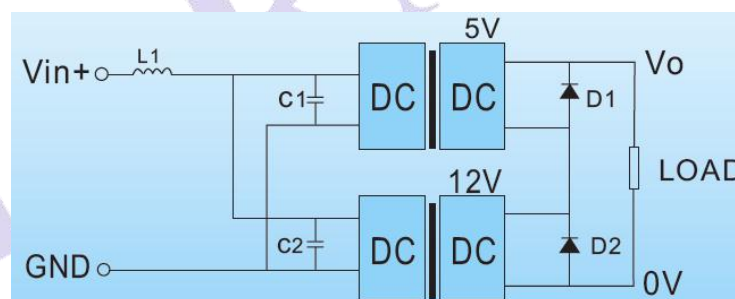

Diagram 3-1 Method 1 of DC/DC Converters connected in series

The first converter outputs 5V, and the second one does 12V. An unconventional voltage of 17V will be generated if they were in series. The total output current is that the load power consumption cannot exceed the minimum output rated current of the converters. Under normal circumstances, the two modules output ripple voltage will not be synchronized. Modules in series will add additional ripple and larger output noise. It's recommended to connect external filters in practical applications.

In the Diagram, the output of each converter is connected in parallel with a reverse

bias diode (generally about Schottky diode of 0.3V with low voltage drop, reason: over voltage drop may damage the product), so as not add reverse voltage to the other converter. Connect a LC filter circuit at the input is to prevent the interference between the converters. In this case, the inductance is generally between 2.2-6.8uH and the capacitor generally between 1.0-4.7uF. However, their values all depend on the actual circuit. Another method to get a higher output voltage is with the help of dual output products, as the following Diagram, and the output is 10V.

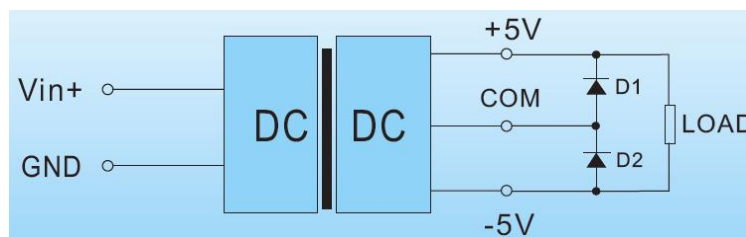

Diagram 3-2 Method 2 of DC/DC Converters connected in series

### B. DC/DC Converters Connected in Parallel

Multiple identical DC/DC Converters in parallel is a redundant design method. It's used to reduce the failure rate and further to improve the reliability of the system. A reminder is that it's not desirable to lift power. Because the output voltage of the two DC/DC converters can not be completely equal and the converter with higher output voltage may provide full load current. Assuming that the two converters have completely equal output voltages, their load current will be unbalanced due to different output impedance, time and temperature changes. In this case, one of the converters may be damaged for overload. Here are some brief introduction to redundant designs:

#### a) For high voltage but low current DC/DC Converters:

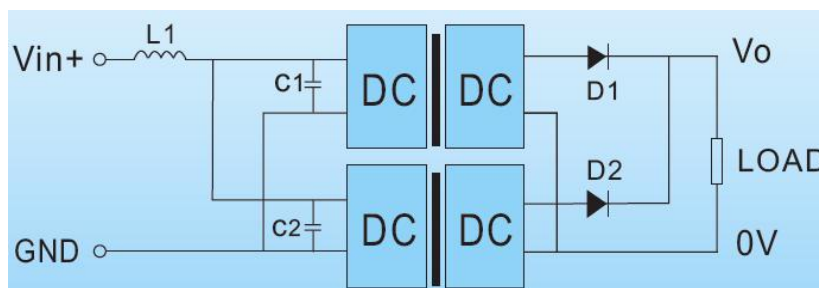

Diagram 3-3 Method 1 of DC/DC Converters connected in parallel

Diagram 3-3 recommends the use of low voltage drop Schottky diodes to avoid the voltage drop affecting the back-end system. Pay attention to, the diode voltage should be higher than the output voltage. An effect is it will produce additional ripple noise. Therefore, external capacitors or filter circuit is needed to reduce the ripple.

**b) For low voltage but high current DC/DC Converters:**

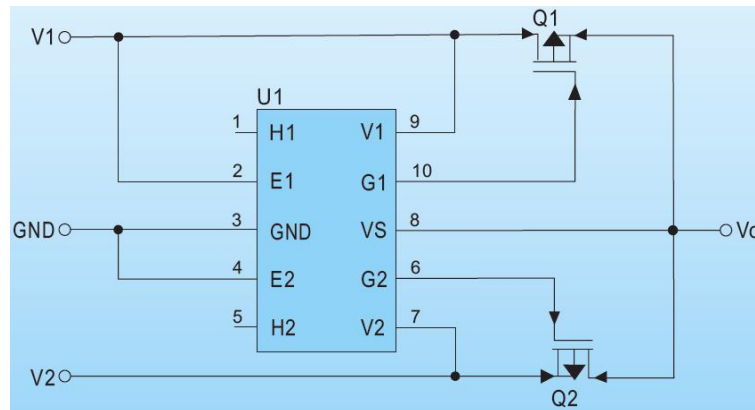

Diagram 3-4 Method 2 of DC/DC Converters connected in parallel

Redundant design of diode will lead to larger power consumption and is not so practical in low-voltage high-current applications. Therefore, it generally uses a high-power MOS tube and chip to replace the diode, easier. MOS tube in the circuit, on one hand, is to reduce the conduction voltage drop. On the other hand, when the input current is large, it reduces the loss of the device and makes products work more effectively.

**c) For applications where single output DC/DC Converters in parallel to get positive and negative output:**

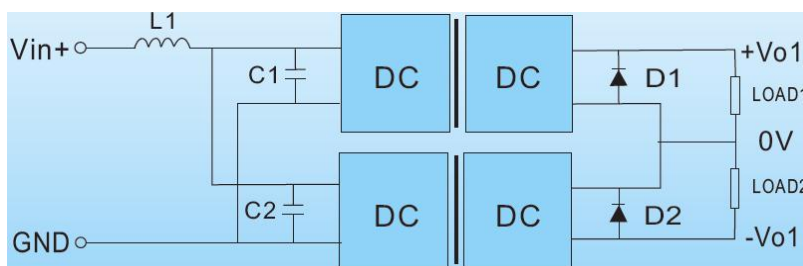

Diagram 3-5 Method 3 of DC/DC Converters connected in parallel

If the difference of required positive and negative outputs in actual application are

big (e.g.: the main circuit should be with heavy load, and the auxiliary circuit with light load), the converter with dual outputs is prone to unbalanced load resulting in excessive voltage accuracy. Not recommended. It is recommended to select two converters according to the requirement of actual load and connect them as above diagram.

When there are over one power supply sharing a bus voltage input, it is recommended to connect an LC filter circuit at the input terminal. Because it may form a reflection of the ripple to the input terminal in the customer's system and cause the power supply's abnormal operation.

### C. Input Reverse Polarity Protection

The circuit is shown as below. It is worth noting that the inputs "Vin +" and "- 48V" should be respectively connected to "0V" and "GND" to ensure the potential difference at input terminal when connecting a negative voltage supply (e.g.: communication field: -48VDC). The voltage drop of the diode D1 in Diagram 3-6 should be as small as possible to avoid too much wire loss, and the reverse withstand voltage should be greater enough than its input voltage and have margin.

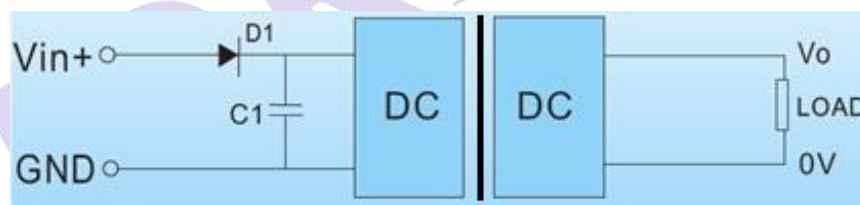

Diagram 3-6 Input reverse polarity protection circuit

### D. Input Under-voltage Protection

When a converter share a same power supply with other circuits, a large drop of input voltage caused by external short circuit or overload will cause the converter's output instability and malfunction. In this case, under-voltage protection circuit will turn off at a certain set voltage value, ensuring the normal operation of the converter, as shown in Diagram 3-7:

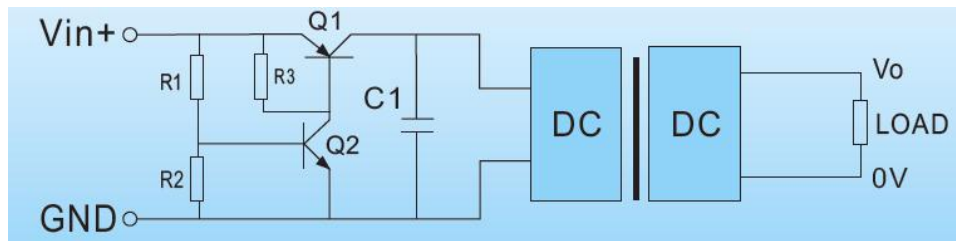

Diagram 3-7 Input under-voltage protection circuit

Resistances R1 and R2 are set as low voltage switching limit. Transistor Q1 in PNP can use P-channel MOS. For example, an input of 5V can set under-voltage protection value at 4-4.5V.

Note: The above circuit will produce a voltage drop about 0.7V. It should pay attention to whether there will be other effects for low-voltage input converter.

### E. Input Over-current and Over-voltage Protection

Short circuit of converters for usually cause over-current or over-voltage due to instability of the power grid in that the converters often produce instantaneous high-energy surge for switch action, arc, lightning induction, which will damage the converter's components or even burn itself. The protection circuit is as follows:

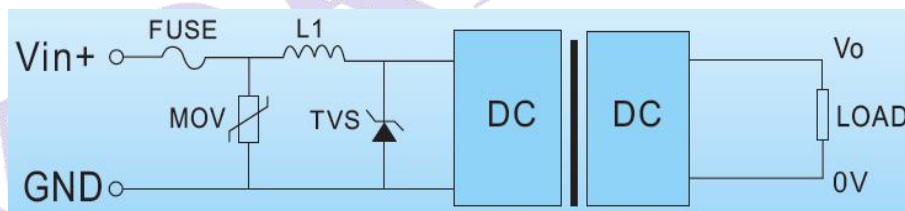

Diagram 3-8 Instant over voltage and over current protection circuit

Note1: Ensure that the fuse can withstand the instantaneous inrush current when switch-on. More information please refer to datasheet.

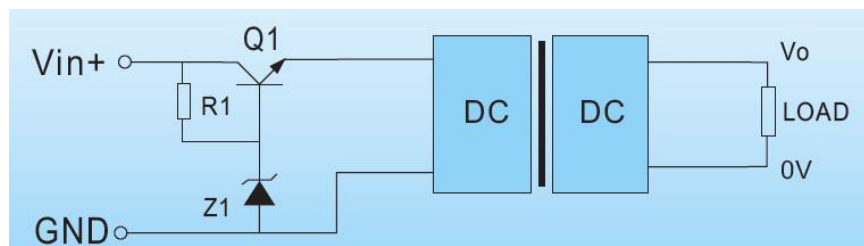

Diagram 3-9 Continuous over voltage protection circuit

Note2: The input value for over-voltage protection can not exceed the maximum one

indicated in the datasheet. E.g.: if the input voltage is 9-36V, the set value for over-voltage protection cannot exceed 40V.

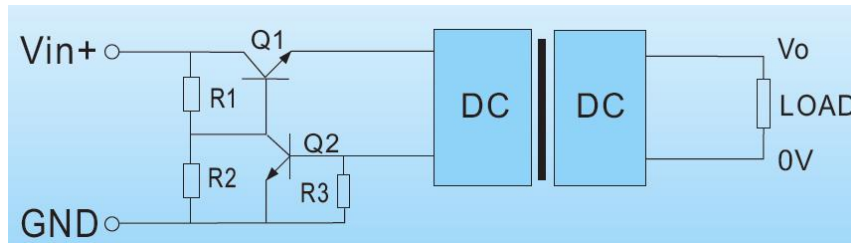

Diagram 3-10 Continuous over current protection circuit

It should detect the input current to achieve over-current protection and choose the appropriate current  $I_{limt}$  (set current value in the circuit for over-current protection). Grounding resistance R3 should be determined together by  $I_{limt}$  and the conduction voltage drop of transistor Q2 VBE. The formula is

$$R3 = \frac{0.7V}{I_{limt}}$$

Please notice the power consumption of resistor R3.

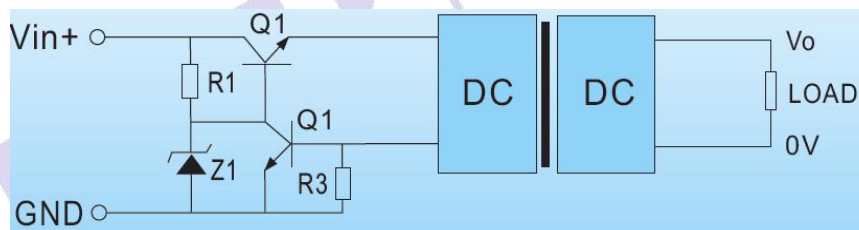

Diagram 3-11 Continuous over voltage and over current protection circuit

## F. Input and Output Filtering Circuit

Filters are usually connected at the input and output terminals of the converters to reduce ripple and noise in applications where are sensitive.

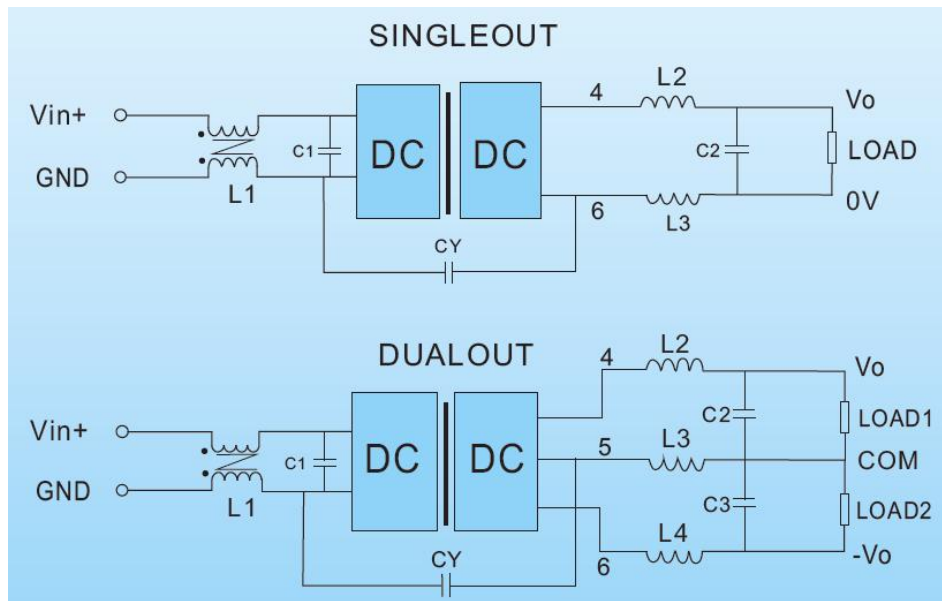

Diagram 3-12 Recommended circuit reducing ripple &amp; noise

Adding a capacitor at the input terminal can absorb the voltage spikes, save the energy and keep the voltage stable. Adding a capacitor at the output terminal can greatly reduce the output ripple, but it's likely to cause the failure of start-up due to too large capacitance or too low ESR. For applications requiring extremely low ripple, using a "LC" filter network or using converters with low ripple is an alternative.

C1: electrolytic capacitors, to reduce input ripple. Its value please refer to datasheet;

L2 / L3 / L4, C2 / C3: forming an LC filter network to reduce the output ripple. The capacitor is suggested to a ceramic capacitor or an electrolytic capacitor with low resistance, whose value is determined according to the actual ripple but cannot exceed the maximum capacitive load;

L1, CY: L1 is a common mode inductor to suppress common mode interference. Y1 is a Y capacitor offering 100-1000pF.

Note:

For the components of the filter circuit, they are generally calculated according to the following formula and the frequency should be one tenth of the converter's switching frequency.

$$f_c = \frac{1}{2\pi\sqrt{LC}}$$

The calculated value of filter may vary due to different application designs and load conditions, so the value must be adjusted in conjunction with the practical application.

When setting the value of the filter capacitor, it cannot exceed the maximum one of the capacitive load indicated in datasheet.

## G. Electromagnetic Interference and Electromagnetic Compatibility

### a) Electromagnetic Interference (EMI)

EMI is the pollution to the environment caused by electromagnetic radiation through the space, the signal line and the wire. It can not be completely eliminated, but can be reduced to a safe level. Certain effective ways to suppress EMI are generally as follows:

- i) to shield EMI radiation: to select the products in metal shielded package or to add additional shield so as to reduce EMI radiation;
- ii) Reasonable grounding;
- ii) to select suitable filters or filter networks to reduce the transmission of EMI from the wire and the signal line;
- iv) to separately layout the converters and the small signal circuit, in order to effectively avoid the interference of the former to the latter.

### b) Electromagnetic Compatibility (EMC)

EMC is the ability of electronic equipment and power supply to work stably and reliably in a certain electromagnetic interference environment. It is also the ability of electronic equipment and power supply to limit their own electromagnetic interference and avoid interference to other electronic equipment.

Improving EMC is available from the following three aspects:

- i) to reduce the radiation of source of EMC interference;
- ii) to shield EMC interference transmission;
- iii) to improve anti-electromagnetic interference of the electronic equipment and power



supply.

According to the way of transmission, EMC interference is divided into:

**i) Conduction interference.** It is the noise generated by the system into the DC input line or signal line. The frequency range is 150KHz-30MHz. Conduction interference has common mode and differential mode. LC network is often used to suppress the conducted interference.

**ii) Radiation interference.** It directly spreads in electromagnetic waves, plays a role of launch antenna and its frequency range is 30MHz-1GHz. Radiation interference can be suppressed by metal shielding.

### c) EMC Solution-recommended Circuit

As DC / DC converters are secondary power supplies, in order to pass EMS test, they usually connect external protection circuit at the DC/DC port or signal port, and add an inductance between TVS and varistor to discharge most of the interference energy. It can combine the TVS's lower clamping voltage and the varistor's larger flow, protecting the back-circuit. Here's the formula to calculate the inductance's value, where  $I_{pp} / 2$  mainly taking a 50% derating of the TVS into account:

$$L = \frac{(U_{c1} - U_{c2}) \times (20 - 8)}{I_{pp} / 2}$$

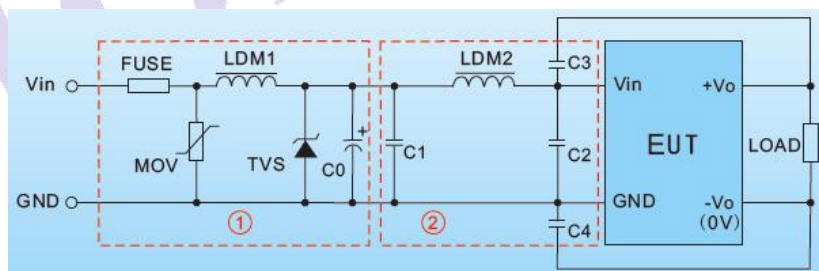

Diagram 3-13 EMC Solution-recommended Circuit

The circuit marked ① is used for EMS to test peripheral circuit. The circuit marked ② is used for EMI filtering and can be selected according to requirements. For more details please refer to datasheet.

### d) Test abnormalities of DC/DC Converters' CE without external components

DC/DC Converters' CE meet CISPR22/EN55022 CLASS A, without external

components, but they alone cannot meet it in terminal applications for excessive base frequency or low frequency. In this case, it should be noted:

(1) There will be a difference of 3-6dB caused by different environments, different test equipment and other factors in different organizations, which belongs to the standard requirements of the normal range.

(2) If only the base frequency exceeded in the test, it should be checked whether the DC/DC Converter tested as the datasheet. However, when DC/DC Converter matches to artificial power network, start failure (input voltage wave fluctuations or power supply over-current) often occurs due to resonance of DC/DC Converter's input capacitance or inductance and artificial power network's inductor. It also lead to test abnormalities. It's recommended to add a 100uF electrolytic capacitor at the input terminal of the converter, to stabilize the converter or increase the input voltage to keep the product stable.

#### H. Capacitive Load

For general switching power supplies, it's recommended to connect electrolytic capacitors at the output terminal to meet the requirements for the maximum capacitive load. But it should be noted that too large capacitance or low ESR (equivalent series resistance) may cause the module to work unstable or bad start-up. For more details please refer to datasheet.

#### I. Pin-out

##### a) TRIM

The output voltage  $\pm 10\%$  around its rated value can be adjusted by adding a resistor at the TRIM terminal. But the total output power of the converter should be within its maximum output power. If the output voltage is higher than its nominal value, lower output current to comply with the maximum output power. If the output voltage is lower than its nominal value, the output current should not exceed the rated current, too.

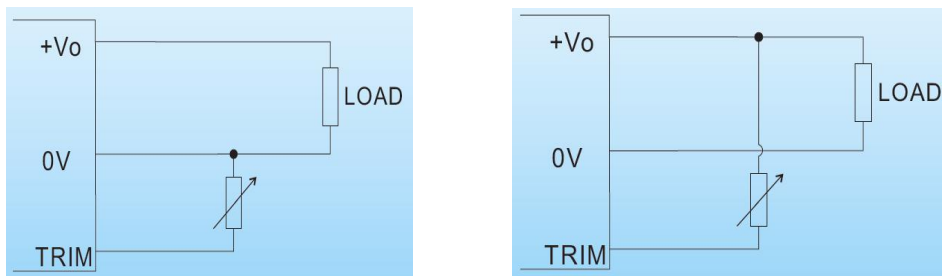

Diagram 3-14 Connection of output voltage's trimming with an external resistor

External resistor connection method is shown in the above diagram. To adjust to a higher output voltage (see left diagram), connecting a resistor between TRIM terminal and output terminal is recommended. To adjust to a lower output voltage (see right diagram), connecting a resistor between TRIM terminal and Vo is recommended. If TRIM is not needed, just no connection.

It also should be noted that the adjustment is a certain range (generally about  $\pm 10\%$ ) and cannot get all required voltages through TRIM. If the required voltage exceeds the range, it may be incompatible to the converter's output over-voltage protection, affecting the normal operation of the converter. In this case, it should take required voltage through other methods.

b) Remote on/off control (sense)

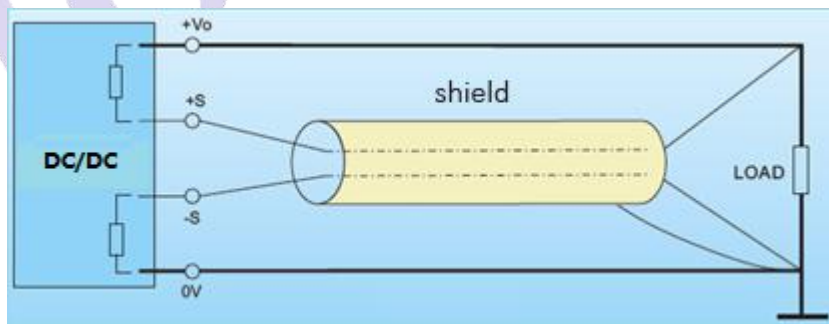

Diagram 3-15 Connection of remote control

DC/DC Converter, in the long-distance transmission, usually uses remote voltage compensation method to improve the input voltage of load, in order to meet the requirement of normal working voltage at full load. The remote voltage compensation method is a method to compensate the input voltage of remote load via pins of + SENSE

and -SENSE. When using the wire for remote connection, it should be noted to shield the wire or use twisted pair, as shown in diagram 3-15, in case causing large EMI interference for external wire connection.

### c) Switch control

Switch control refers to the converter's output voltage operation of "ON" (enabled) and "OFF" (disabled). There are two standard methods to switch the converter.

Positive logic: CTRL control pin connects with -Vin, output OFF. CTRL control opens or connects high level, output ON.

Negative logic: CTRL control pin connects with -Vin, output ON. CTRL control opens, output OFF.

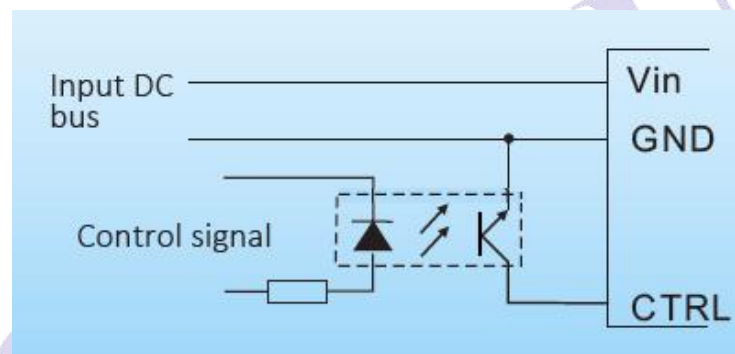

Diagram 3-16 Isolation control method

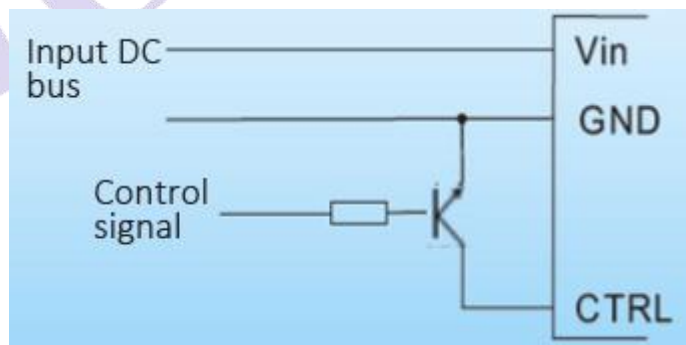

Diagram 3-17 Common control method

In special applications, isolation control method is usually used as shown in diagram 3-16. MORNSUN DC/DC converters are divided into voltage control and current control.

VR and UR Series: Adjust the converter's power-on and power-off via CTRL control

pin provides a control voltage. When the CTRL control pin voltage is less than 1.2VDC or directly connected to the input ground, the converter is power-off. When the CTRL control pin voltage is 2.5-12VDC (the CTRL control pin is at high level compared to input ground) via external power supply or itself, the converter is power-on.

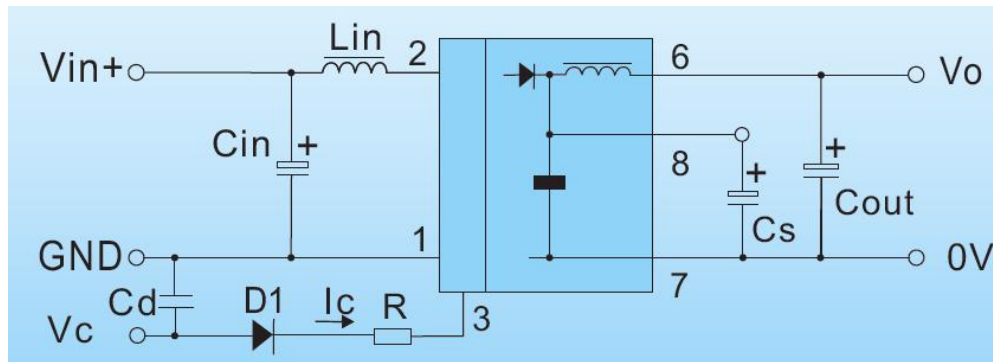

Diagram 3-18 CTRL of WR Series

WR Series: When the CTRL pin is no connection or in high impedance state, the converter works normally.

When powers off the converter, get a control voltage  $V_c$  via a resistor  $R$  and the CTRL pin (the CTRL pin is at high level compared to input ground), set current of the pin 5-10mA and shutdown MOS. The calculation formula of resistance is:

$$R = \frac{V_c - V_d - 1.0}{I_c} - 300$$

Attention: The series' CTRL pin cannot be connected with the input ground or low level. Otherwise, it may cause short circuit of the input terminal (MOSFET), or even damage the converter.

It should change the voltage of the CTRL pin to control the converter's power-on or power-off depending on practical applications and datasheet, when using converters with CTRL pin. If CTRL is not needed, just no connection. If there is some interference in the actual circuit, it is recommended to protect from interference (away from the interference source) in case causing the converter's malfunction or damage.

## IV. FAQs

### A. Do MORNSUN's DC/DC converters support hot-plug?

"Hot-plug", simply refers to directly unplug or plug converters in the system without power-off.

The converters is not allowed to hot-plug during operation in that it will produce several times or even more of large current and voltage spikes of the converters, affecting internal components and damaging the converters in worse circumstances. Therefore, the converters don't support hot-plug.

### B. Can MORNSUN's DC/DC converters be used at no-load or light-load?

The converters can be used at no-load or light-load applications. However, under this condition, the conversion efficiency of the converters is relatively low and some indicators may not meet the requirements of datasheet. From the view of reliability, it's better to avoid these applications and the minimum output current of the converters should be no less than 10% of rated one (R2 DC/DC converters should be 5%). It's suggested to use the converters at 30-80% load or choose the converters with lower power. Note: R3 DC/DC converters can be used at no-load.

### C. Reasons cause failures of MORNSUN's DC/DC converters?

Reason 1: In actual application, the capacitive load exceeds the maximum value indicated in datasheet. Larger output capacitor requires larger starting current, which will cause the failure of the converters. To reduce the output capacitance at the output terminal or connect buffer circuit is a good choice to increase the capacity of the converters.

Reason 2: Limited to the maximum power provided by the intrinsically safe power supply, the starting power cannot meet the requirements of the converters (the converters require a large starting power at start-up). It is recommended to select the products with small starting current or connect a small resistance or NTC at the input terminal of the converters to reduce the start current.

Reason 3: the inductive load (usually motor coil) does not produce induced electromotive force when starting up. Only the coil's resistor  $r$  works in the entire loop, will resistance be very small (usually  $m\Omega \sim \Omega$  level). According to  $I = \frac{V}{r}$ , the current will be larger to over the over-current protection value of the converters, resulting in the protection of the converters, namely, failures of them. It is recommended to connect a small resistor in series at the output terminal for converters with low power, or select a power supply with larger power.

#### **D. High standby power consumption for converters over 20W?**

MORNSUN DC/DC Converters, which offer powers of 20-30W outputting 3.3V and 5V and over 50W, apply a synchronous rectification design. Therefore, standby power consumption is relatively large and for more details please refer to datasheet.

#### **E. Operating temperature?**

When DC/DC Converters work in high temperature environment, their internal components' temperature is much higher than the ambient temperature. In order to ensure the reliability of the converters, the highest environmental operating temperature of conventional converters is 85 °C. When the ambient temperature reached 55 °C or 60 °C, the converters need derating (specific derating curve need to refer to datasheet). When the ambient temperature is low to -40 °C, the converters needn't derating.

#### **F. Dual outputs, and load imbalance?**

The feedback loop of DC/DC Converters with multiple outputs only take the primary circuit's voltage. Load imbalance will lead to poor voltage accuracy, so it should refer to datasheet to the ensure load balance in applications. Generally, the load differences of each output should be between  $\pm 5$ . Load balance can also be achieved by external dummy load in conventional applications.

#### **G. Power-down sequences for DC/DC Converters with multiple outputs?**

For DC/DC Converters with multiple outputs, the auxiliary circuit voltage is obtained through the transformer coupling, and its power-down sequence relative to the load.

Once the primary circuit voltage drops to 0, the auxiliary circuit will not output voltage.

## H. Measures suppressing noise?

For DC/DC Converters, noise within 20 MHz can be reduced using LC filtering or  $\pi$  filtering, and noise of 100M or 200M should be filtered using a common mode inductor and a capacitor.

MORNSUN