

## Fixed Input Voltage DC/DC Converters Application Guide 2017

<b>I. Selection Guide.....</b>	<b>2</b>
A. Selecting Power Supply.....	2
B. Designing Power Distribution System.....	3
<b>II. DC/DC Converter Testing Suggestions.....</b>	<b>6</b>
A. Testing the Circuit Itself.....	6
B. Testing Converter's Performance.....	7
<b>II. Applications of DC/DC Converters.....</b>	<b>14</b>
A. DC/DC Converters Connected in Series.....	14
B. DC/DC Converters Connected in Parallel.....	15
C. Input Reverse Polarity Protection.....	17
D. Input Under-voltage Protection.....	18
E. Input Over-current and Over-voltage Protection.....	18
F. Input and Output Filtering Circuit.....	19
G. Electromagnetic Interference and Electromagnetic Compatibility.....	21
H. Capacitive Load.....	23
<b>III. FAQs.....</b>	<b>23</b>
A. Do MORNSUN's DC/DC converters support hot-plug?.....	23
B. Can MORNSUN's DC/DC converters be used at no-load or light-load?.....	23
C. Reasons cause failures of MORNSUN's DC/DC converters?.....	24
D. Is it available to connect a tantalum capacitor at input and output terminals of MORNSUN's DC/DC converters?.....	24

## I. Selection Guide

### A. Selecting Power Supply

The first step is to confirm specifications of the power supply and then determine to choose a standard power supply module or a customized one according to requested parameters. Whole steps show in the following flow chart.

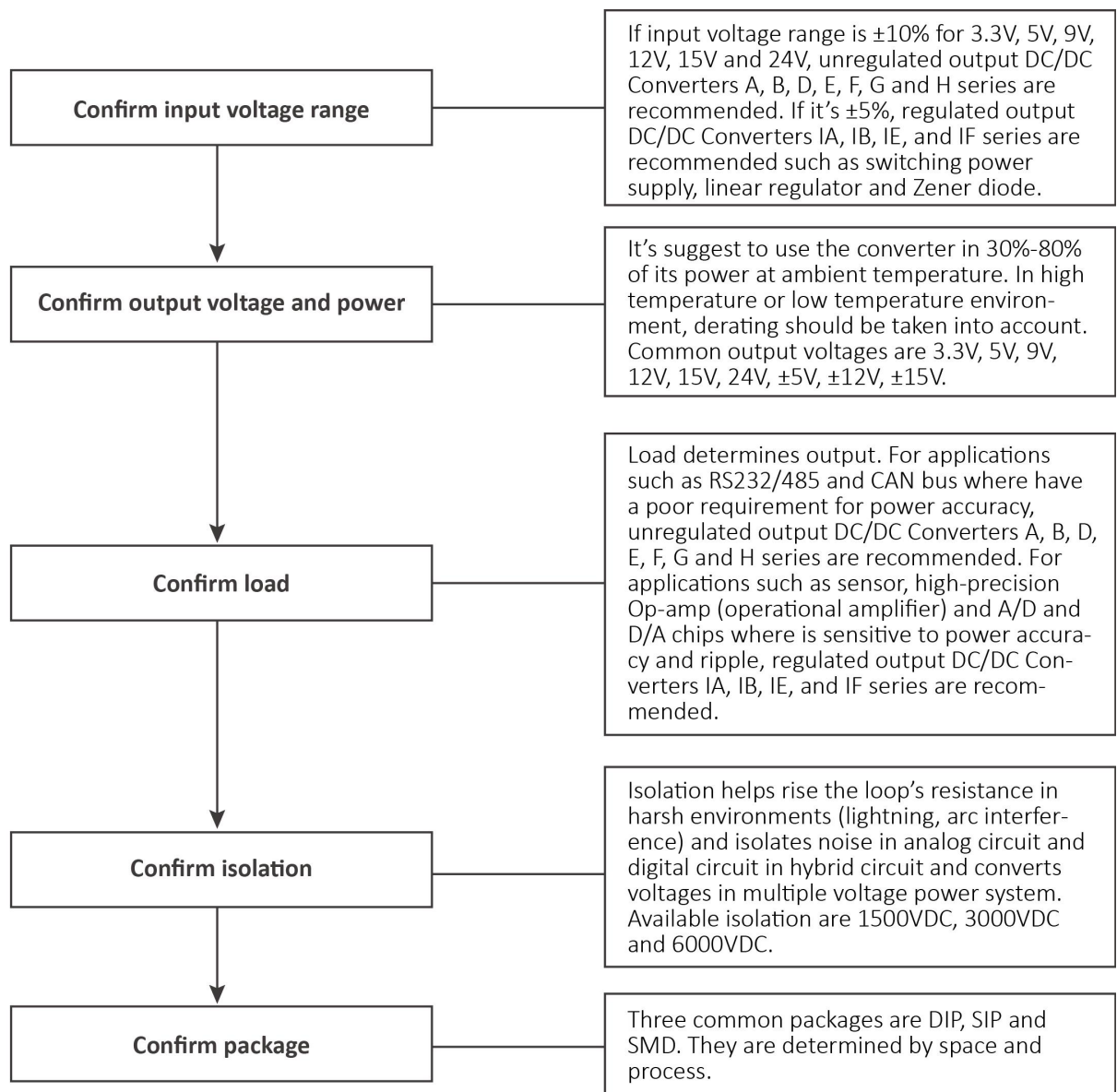

Diagram 1-1 Steps of selecting power supply

Table 1-1 Layout of MORNSUN fixed input DC/DC Converters

Product lines	Input voltage range	Isolation	Single output	Double outputs
Fixed input, regulated output	$\pm 5\% V_{in}$	1000VDC	IB series	None
		3000VDC	IF series	None
Fixed input, unregulated output	$\pm 10\% V_{in}$	1500VDC	B series	A series
		3000VDC	F series	E series
		6000VDC	H series	G series
Fixed input, unregulated output	$\pm 10\% V_{in}$	1500VDC	B series	A series
		3000VDC	F series	E series
		6000VDC	H series	G series

## B. Designing Power Distribution System

Products' features and circuit's requirements should be taken into consideration when engineers design a power distribution system. And they have to optimize the system several times, by which acquires accurate operating parameters and environmental changes of practical circuits to precisely choose suitable converters.

### Step one, mind ambient factors.

Ambient factors include ambient temperature, transmission distance and so on.

Ambient temperature can affect converters and external components. Considering that the converters are used in high temperature, low temperature or high and low temperature cycle (such as: engine room and cabin), corresponding parameters may change. Engineers should clearly know these changes and design correct circuit in this application. It should be noted here that the ambient temperature of power module refers to the internal temperature of device rather than ambient temperature. The former is usually higher than the latter in that the device contains many heat generating components.

Table 1-2 Industry working temperature distribution

Industries	Working temperature
Commerce	0-70°C
Industry	-40-85°C
Vehicle on-board equipment	-40-105°C
Field exploration instrument	-55-85°C
Military	-55-125°C

It also should be noted that the module derates significantly at high temperature. In this case, the chosen converter should allow significant deration and connect an electrolytic capacitor with excellent high and low temperature. Please refer to datasheet when selecting the capacitor whose withstand voltage reduces as well at high temperature.

Transmission distance is another factor affecting converters and external components. General suggestions are:

a) Non-isolation or low power converters are the first choice for indoors for its short distance, little temperature drop and weak interference.

b) Wide input and isolated, high-efficiency converters are the best choices for long-distance transmission. In addition to lightning protection, accurate transmission loss should be calculated.

c) It is recommended that start-up current of converter supplied by the power supply is 1.3 -1.6 times to ensure normal operation of the converter, resulting from long-distance transmission and large loss.

d) It is recommended to connect a capacitor at the input terminal of the converter to improve start-up performance itself.

Other ambient factors are interference caused by arc, electrostatic discharge, unstable AC, start-up switches, relays and lightning. As a result, input voltage and current may go far beyond the converter's tolerance and cause permanent damage to the

converter and paralysis of the load circuit. In this case, there's no better choice to add protection circuit ensuring the safety.

### **Step two, mind working circumstance.**

A common sense is that all converters lose certain power and change it into their own heat energy, which will make surrounding environment warmer. Further, it causes data interference (thermal sensor) and performance degradation of device and even causes short-circuit to fire. Thus, larger ventilation or heat dissipation space to reduce temperature rise is essential to ensure safety.

As DC/DC converters adopt switching technology, their own switching oscillator circuit and internal magnetic components will produce electromagnetic interference and pollution to surrounding ones by conduction and radiation (note: electromagnetic interference, shorting for EMI, refers to pollution from electromagnetic energy that affects environment by electromagnetic radiation and conduction). EMI cannot be completely eliminated, but can be reduced to a safe level by certain measures for electromagnetic compatibility.

### **Step three, mind layout.**

Unreasonable grounding and layout easily tend to cause unstable system, high noise and other undesirable phenomena.

In many applications, analog circuit and digital circuit share the same power supply, in which it is very important to separately use them or completely isolate the power supply from ground loop. It aims to avoiding the interference from digital DC voltage drop variation and logic suppressor process to analog circuit system.

In high-speed/dynamic analog circuit or digital circuit, the distributed resistance and inductance become noticeable and easily cause noise spikes for rapid changes of load current when the wire is long. In this case, load decoupling and eliminating resonance are recommended which is caused by distributed parameter.

## II. DC/DC Converter Testing Suggestions

Product's performance in practical application is also vital except a right power supply. Therefore, it needs to be tested and verified before use. Common test methods are available as follow:

### A. Testing the Circuit Itself

Kelvin-style test method is a standard one as shown in diagram 2-1. Test conditions: ambient temperature  $T_a=25^{\circ}\text{C}$ , humidity  $<75\%$ .

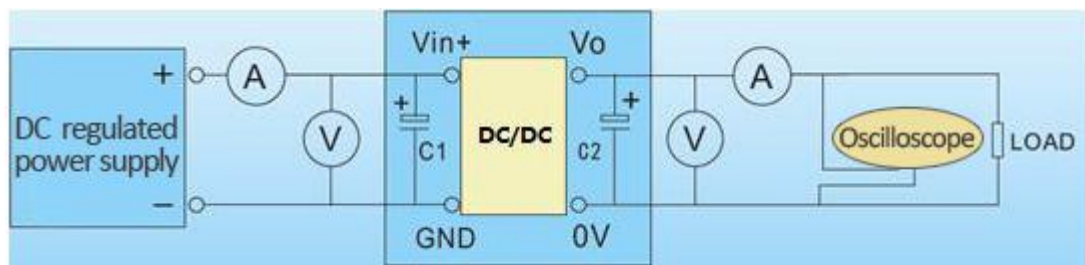

Diagram 2-1 Kelvin-style test method

Test instrument: DC adjustable regulated power supply (wide enough input voltage range), ammeter A (accuracy: 0.001A), voltmeter V (accuracy: 0.001V), load resistance (rated load:  $\frac{V_o^2}{P}$ , light load:  $10\% \times \frac{V_o^2}{P}$ )

Notes:

a) Wire connection: the less wire loss, the better it is. A multi-strand copper wire with 1mm diameter is the best choice to avoid excessive voltage drop. When the load current is large, it should shorten distances between output pins and the load, and increase cross-sectional area of the connecting wire to reduce the excessive voltage drop.

b) Grounding: Improper grounding can cause unintended noise in the circuit. When testing ripple and noise, it is suggested to test output by using contact measuring method with a single pole, in case causing measurement errors. Contact measuring method helps reduce external interference and the single pole does common ground of input and output. (See "ripple and noise")

c) Load: To acquire accurate voltage and ripple under a correct current limiting

point of front-circuit, output capacitive load should be within rated one at 10%-100% load.

For more details please refer to datasheet.

## B. Testing Converter's Performance

Performance testing begins with correct connections of power modules, by which to confirm whether parameters meet requirements or not.

### a) Output voltage accuracy

Set input voltage at nominal value, and tested output voltage will be  $V_{nom}$ .

$V_{outnom}$ : nominal output voltage at nominal input voltage and rated load	Output voltage
$V_{out}$ : tested output voltage at nominal input voltage	accuracy = $\frac{V_{out} - V_{outnom}}{V_{outnom}} \times 100\%$

e.g. (B1212LS-1WR2):  $V_{outnom}=12V$ , rated load= $144\Omega$ ,  $V_{out}=12.039V$ ,

$$\text{Output voltage accuracy} = \frac{12.039 - 12.000}{12.000} \times 100\% = 0.325\%$$

### b) Line regulation

i): Fixed input, isolated unregulated series (series prefixed with A, B, C, D, E, F, G, H, J):

$V_{in+10\%}$ : nominal input voltage and add 10% as its upper limit	$\Delta V_{out} = \frac{V_{out+10\%} - V_{out-10\%}}{V_{outnom}} \times 100\%$
$V_{in-10\%}$ : nominal input voltage and minus 10% as its lower limit	
$V_{out+10\%}$ : output voltage at full load when input voltage at its upper limit	$\Delta V_{in} = \frac{V_{in+10\%} - V_{in-10\%}}{V_{innom}} \times 100\%$
$V_{out-10\%}$ : output voltage at full load when input voltage at its lower limit	
$V_{innom}$ : nominal input voltage	Line regulation = $\left  \frac{\Delta V_{out}}{\Delta V_{in}} \right $
$V_{outnom}$ : nominal output voltage	

e.g. (B0505LS-1WR2): rated load= $25\Omega$ ,  $V_{in+10\%}=5.5V$ ,  $V_{innom}=5V$ ,  $V_{outnom}=5V$ ,

$V_{out+10\%}=5.32V, V_{out-10\%}=4.2V$

$$\Delta V_{out} = \frac{5.32V - 4.2V}{5V} \times 100\% = 22.4\%, \quad \Delta V_{in} = \frac{5.5V - 4.5V}{5V} \times 100\% = 20\%$$

$$\text{Line regulation} = \left| \frac{\Delta V_{out}}{\Delta V_{in}} \right| = 1.12$$

ii): Fixed input, isolated regulated series (series prefixed with IA, IB, IE, IF):

$V_{outnom}$ : output voltage at nominal input voltage and rated load	<p>Line regulation</p> $= \frac{V_{mdev} - V_{outnom}}{V_{outnom}} \times 100\%$
$V_{outh}$ : output voltage at rated load when input voltage at its upper limit	
$V_{outl}$ : output voltage at rated load when input voltage at its lower limit	
$V_{mdev}$ : $V_{outh}$ or $V_{outl}$ which is deviated from $V_{outn}$ more	

e.g. (IB2405S-3WR2): rated load=600mA,  $V_{outh}=5.01V, V_{outl}=5.00V, V_{outnom}=5.01V,$

$$\text{Line regulation} = \frac{5.00 - 5.01}{5.01} \times 100\% = -0.2\%$$

### c) Load regulation

i): Fixed input, isolated unregulated series (series prefixed with A, B, C, D, E, F, G, H, J):

$V_{outnl}$ : output voltage at nominal input voltage and 10% load	<p>Load regulation</p> $= \frac{V_{outnl} - V_{outfl}}{V_{outfl}} \times 100\%$
$V_{outfl}$ : output voltage at nominal input voltage and full load	

e.g. (B0505S-1WR2): rated load=25Ω,  $V_{outnl}=5.29V, V_{outfl}=4.77V,$

$$\text{Load regulation} = \frac{5.29V - 4.77V}{4.77V} \times 100\% = 10.9\%$$

ii): Fixed input, isolated regulated series (Series prefixed with IA, IB, IE, IF):



$V_{b1}$ : output voltage at nominal input voltage and 10% load	<b>Load regulation</b>  $= \frac{V_b - V_{b2}}{V_{b2}} \times 100\%$
$V_{b2}$ : output voltage at nominal input voltage and full load	
$V_{b0}$ : output voltage at nominal input voltage and 50% load	
$V_b$ : $V_{b0}$ or $V_{b1}$ which is deviated from $V_{b2}$ more	

#### d) Efficiency

$V_{in}$ : nominal input voltage  $I_{out}$ : output current at full load  $V_{out}$ : output voltage at nominal input voltage and full load  $I_{in}$ : input current	<b>Efficiency</b>  $\eta = \frac{I_{out} \times V_{out}}{I_{in} \times V_{in}} \times 100\%$
--	--

e.g. (B1212LS-1WR2):  $V_{in}=12V$ ,  $V_{out}=11.951V$ ,  $I_{out}=83.6mA$ ,  $I_{in}=100.7mA$ ,

$$\eta = \frac{0.0836 \times 11.951}{0.1007 \times 12.000} \times 100\% = 82.68\%$$

#### e) Ripple and noise

Ripple and noise is the periodic and random AC variation superimposed on DC output, which affects output accuracy and usually is calculated with peak-to-peak (mVP-P).

First, set oscilloscope bandwidth 20MHz to effectively prevent high-frequency noise.

Second, test with parallel cable measuring method, twisted-pair cable measuring method or contact measuring method.

Below testing is with parallel cable measuring method.

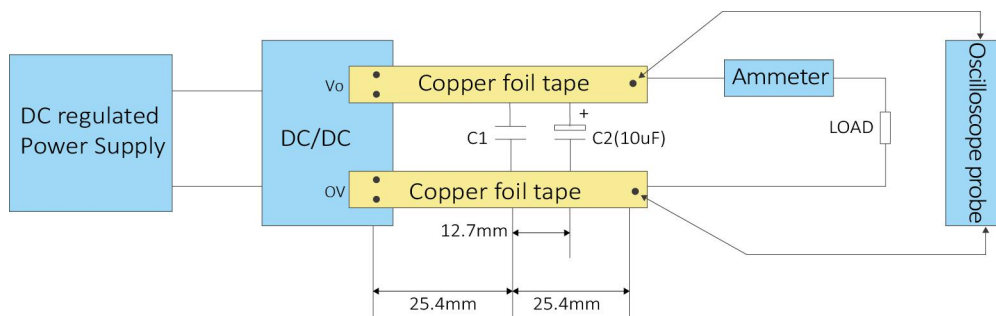

Diagram 2-2 Parallel cable measuring method

Notes:

- C1: a ceramic capacitor with 0.1uF capacitance.
- C2: a capacitor suitable for fixed input products (series prefixed with A, B, C, D, E, F, G, H, J, IA, IB, IE, IF). For more details please refer to datasheet.
- Distance between two paralleled copper foils is 2.5 mm and, of which the sum of voltage drops should be less than 2% of nominal output voltage.

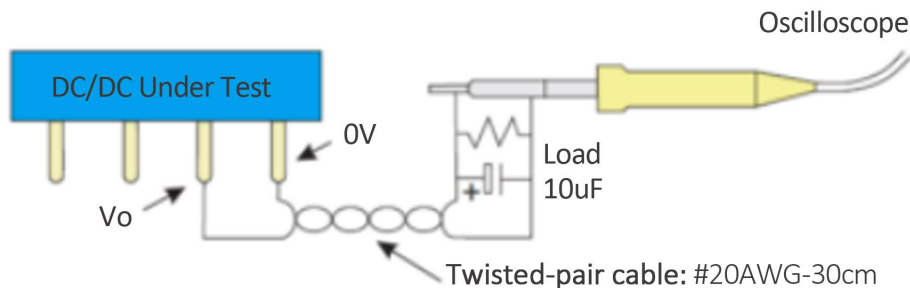

Diagram 2-3 Twisted-pair cable measuring method

Another testing is with twisted-pair cable measuring method as shown above in diagram 2-3. Connect tested power supply Vo and 0V with a twisted-pair cable which is composed of 30cm long and #20AWG, and then connect a dummy load between them. Next, connect a 10  $\mu$  F electrolytic capacitor at the end of the twisted-pair cable, which connects the end of oscilloscope's probe at one terminal and connects the ground at the other.

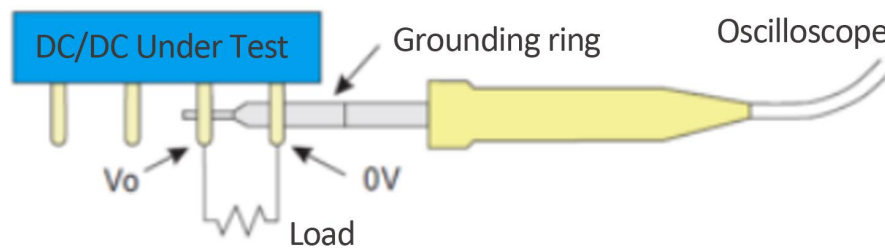

Diagram 2-4 Contact measuring method with oscilloscope

Contact measuring method, as shown in diagram 2-4, is usually adopted for oscilloscope to shield interference. Because the oscilloscope's ground clip could absorb various high-frequency noise, affecting test results. Whatever single output or double outputs or more, the test method is similar. Connect a oscilloscope probe to each output terminal. Then actual tested ripple and noise will vary depending on different circuit and external components. Diagram 2-5 shows the actual tested ripple and noise waveform.

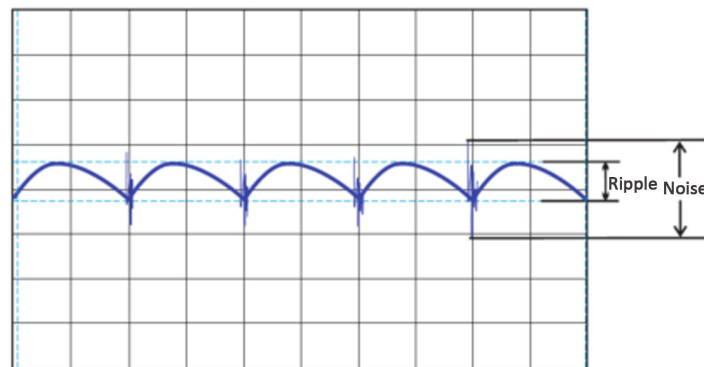

Diagram 2-5 Waveform of Ripple &amp; Noise Test

#### f) Start-up time

Start-up time refers to corresponding delay time during which input voltage exists and output voltage reaches to a targeted value, which is usually tested at rated full load. In practical design, taking start-up time and ripple and noise into consideration together is recommended in that external filter including input or output capacitor will greatly delay the time. Fixed input DC/DC Converter adopts open-loop design, thus they have fast start-up time. For more details please refer to datasheet or contact our sales department.

Diagram 2-6 shows the actual tested start-up time waveform.

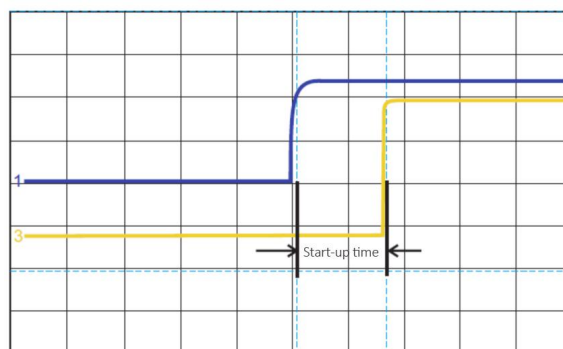

Diagram 2-6 Waveform of Start-up Time Test

### g) Isolation and insulation

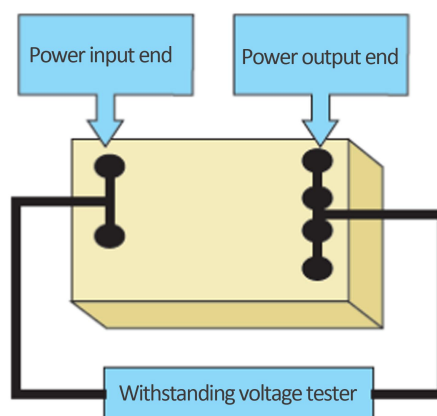

Diagram 2-7 Method of Withstand Test

**Withstand test:** Following withstand test standards, withstand value shall be set from 0 slowly upward and remain 1 minute at the maximum rated isolation.

**Insulation test:** measure it for 1 minute by applying isolation voltage between the input and output.

**Insulation resistance:** the value should be above 1GOhm when applying 500VDC from input/output.

Isolation voltage shown in datasheet is only valid for a one-minute quick test. Therefore, rated working voltage must refer to relevant standard if it's required longer operation at high withstand voltage. And the switching relationship between the isolation voltage and the rated working voltage, according to the IEC950 standard, is shown as

Diagram 2-8. Standard typical breakdown voltage of IEC950 is shown in Table 2-1.

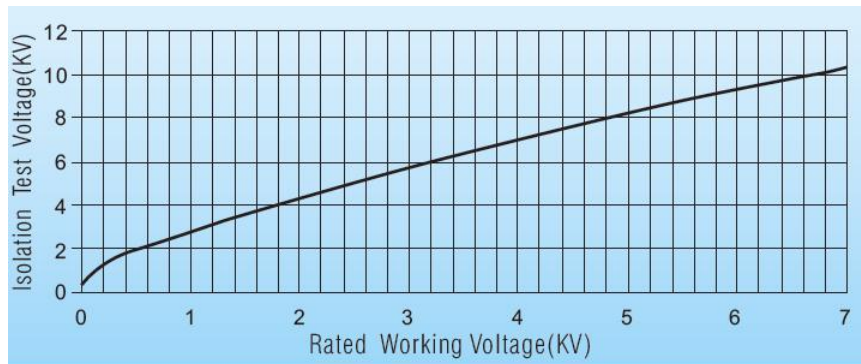

Diagram 2-8 Relationship between Isolation Test Voltage and Rated Working Voltage

Table 2-1 Typical Breakdown Voltage Ratings According to IEC950

Isolation Test Voltage (Vrms)	Rated Working Voltage (Vrms)
1000	130
1500	230
3000	1100
6000	3050

## h) Temperature rise test

Temperature rise test is usually with the help of thermal imager or thermocouple. The former can be affected and lead to a certain deviation in measurement results due to the emissivity. Therefore, the latter, test with thermocouple, is recommended.

For example, given that the ambient temperature  $T_a$  is  $25^{\circ}\text{C}$ , and the measured temperature of power supply  $T_c$  is  $60^{\circ}\text{C}$ . Then the temperature rise  $\Delta T$  is  $35^{\circ}\text{C}$  ( $\Delta T$  is  $35 = T_c - T_a = 60^{\circ}\text{C} - 25^{\circ}\text{C} = 35^{\circ}\text{C}$ ).

Test: power supply is in nominal voltage input and at rated power.

Note: Temperature of power supply varies due to different power, material of case and internal design, etc. Under the same condition, a metal case has better heat dissipation, lower temperature of internal component and higher reliability than a plastic one. Therefore, it's recommended, in a closed environment, to keep away power supply

from components that sensitive to temperature or isolate them for no natural ventilation.

**i) Input Reflection Ripple Current Test**

The input reflection ripple current mainly refers to the periodic and random AC variation superimposed on DC output which is reflected by the converter. It needs an inductor and capacitor elements connected at its front-end to match the source impedance, as shown in Diagram 2-9. Inductance capacitance recommended values:  $L_{in}$  ( $4.7 \mu H$ ),  $C_{in}$  ( $220 \mu F$ ,  $ESR < 1.0 \Omega$  at  $100 KHz$ )

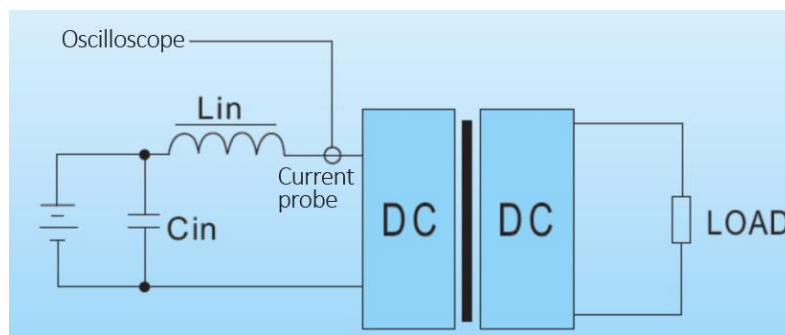

Diagram 2-9 Input Reflection Ripple Current Test

**II. Applications of DC/DC Converters**

**A. DC/DC Converters Connected in Series**

DC output isolation module allows multiple modules in series. "Positive output" of one DC/DC Converter connects with "negative output" of the other DC/DC Converter one by one, as shown in Diagram 3-1, which results in certain unconventional or higher voltage values.

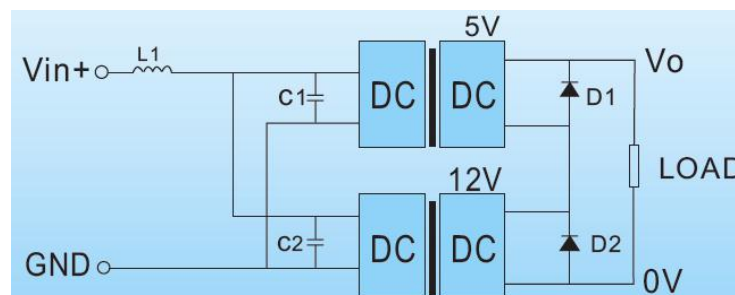

Diagram 3-1 Method 1 of DC/DC Converters connected in series

The first converter outputs 5V, and the second does 12V. An unconventional voltage

of 17V will be generated if they were in series. The total output current is that the load power consumption cannot exceed the minimum output rated current of the converters. Under normal circumstances, the two modules output ripple voltage will not be synchronized. Modules in series will add additional ripple and larger output noise. It's recommended to connect external filters in practical applications.

In the figure, the output of each converter is connected in parallel with a reverse bias diode (generally about Schottky diode of 0.3V with low voltage drop, reason: over voltage drop may damage the product), so as not add reverse voltage to the other converter. Connect a LC filter circuit at the input is to prevent the interference between the converters. In this case, the inductance is generally between 2.2-6.8uH and the capacitor generally between 1.0-4.7uF. However, their values all depend on the actual circuit. Another method to get a higher output voltage is with the help of dual output products, as the following figure, and the output is 10V.

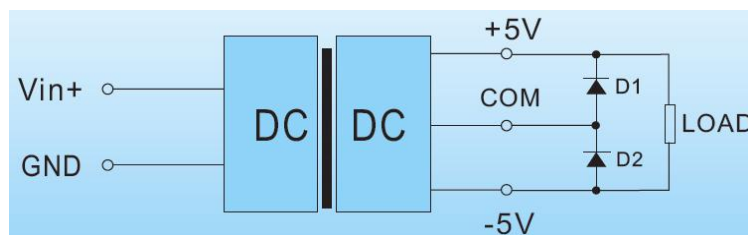

Diagram 3-2 Method 2 of DC/DC Converters connected in series

## B. DC/DC Converters Connected in Parallel

Multiple identical DC/DC Converters in parallel is a redundant design method, which is used to reduce the failure rate and further to improve the reliability of the system. A reminder is that it's not desirable to lift power. Because the output voltage of the two DC/DC converters can not be completely equal and the converter with higher output voltage may provide full load current. Assuming that the two converters have completely equal output voltages, their load current will be unbalanced due to different output impedance, time and temperature changes. In this case, one of the converters may be damaged for overload. Here are some brief introduction to redundant designs:

**a) For high voltage but low current DC/DC Converters:**

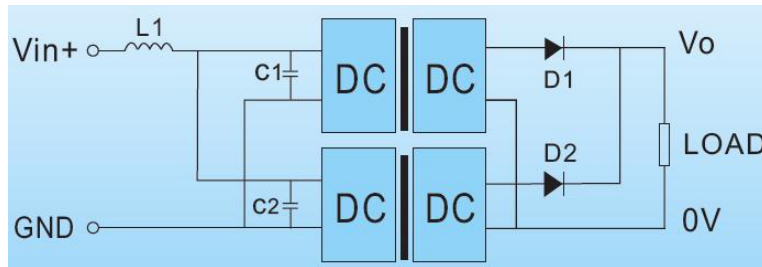

Diagram 3-3 Method 1 of DC/DC Converters connected in parallel

Diagram 3-3 recommends the use of low voltage drop Schottky diodes to avoid the voltage drop affecting the back-end system. Pay attention to, the diode voltage should be higher than the output voltage. An effect is that it will produce additional ripple noise. Therefore, external capacitors or filter circuit is needed to reduce the ripple.

**b) For low voltage but high current DC/DC Converters:**

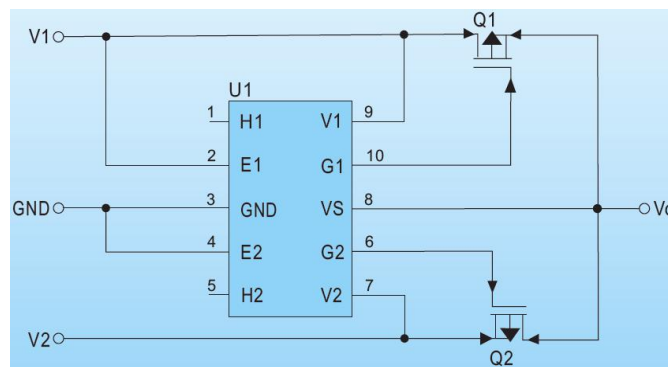

Diagram 3-4 Method 2 of DC/DC Converters connected in parallel

Redundant design of diode will lead to larger power consumption and is not so practical in low-voltage high-current applications. Therefore, it generally uses a high-power MOSFET and its driver to replace the diode, easier. The MOSFET in the circuit, on one hand, is to reduce the conduction voltage drop. On the other hand, when the input current is large, it reduces the power loss of the device and makes products work more effectively.

**c) For applications where single output DC/DC Converters in parallel to get positive and negative output:**



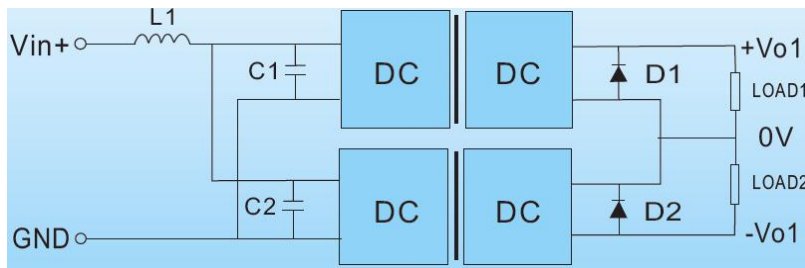

Diagram 3-5 Method 3 of DC/DC Converters connected in parallel

If the difference of required positive and negative outputs in actual application are big (e.g.: the main circuit should be with heavy load, and the auxiliary circuit with light load), the converter with dual outputs is prone to unbalanced load resulting in excessive voltage accuracy. Not recommended. It is recommended to select two converters according to the requirement of actual load and connect them as above diagram.

When there are over one power supply sharing a bus voltage input, it is recommended to connect an LC filter circuit at the input terminal. Because it may form a reflection of the ripple to the input terminal in the customer's system and cause the power supply's abnormal operation.

### C. Input Reverse Polarity Protection

The circuit is shown as below. It is worth noting that the inputs "Vin +" and "- 48V" should be respectively connected to "0V" and "GND" to ensure the potential difference at input terminal when connecting a negative voltage supply (e.g.: communication field: -48VDC). The voltage drop of the diode D1 in Diagram 3-6 should be as small as possible to avoid too much wire loss, and the reverse withstand voltage should be greater enough than its input voltage and have margin.

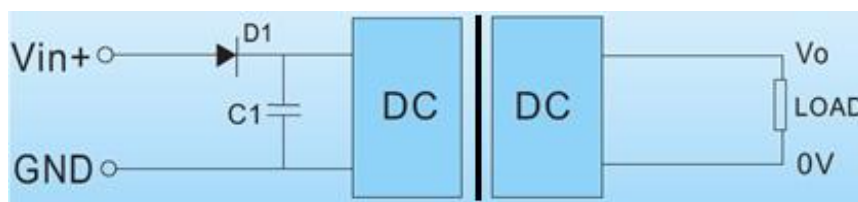

Diagram 3-6 Input reverse polarity protection circuit

#### D. Input Under-voltage Protection

When a converter shares a same power supply with other circuits, a large drop of input voltage caused by external short circuit or overload will cause the converter's output instability and malfunction. In this case, it is recommended to design a under-voltage protection circuit which would turn off at a set voltage value, ensuring the normal operation of the converter, as shown in Diagram 3-7:

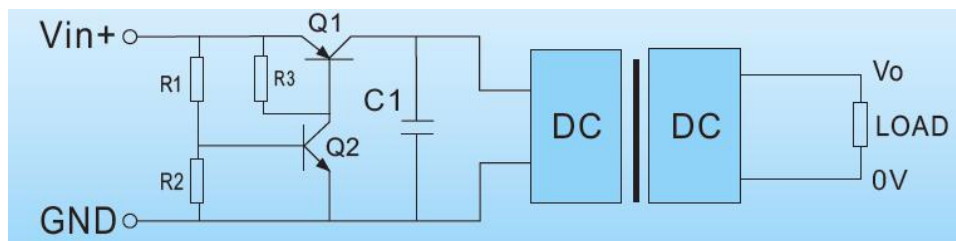

Diagram 3-7 Input under-voltage protection circuit

Resistances R1 and R2 are set as low voltage threshold. Transistor Q1 in PNP can use P-channel MOS. For example, an input of 5V can set voltage threshold at 4-4.5V.

Note: The above circuit will produce a voltage drop about 0.7V. It should pay attention to whether there will be other effects for low-voltage input converter.

#### E. Input Over-current and Over-voltage Protection

Short circuit of converters for usually cause over-current or over-voltage due to instability of the power grid in that the converters often produce instantaneous high-energy surge for switch action, arc, lightning induction, which will damage the converter's components or even burn itself. The protection circuit is as follows:

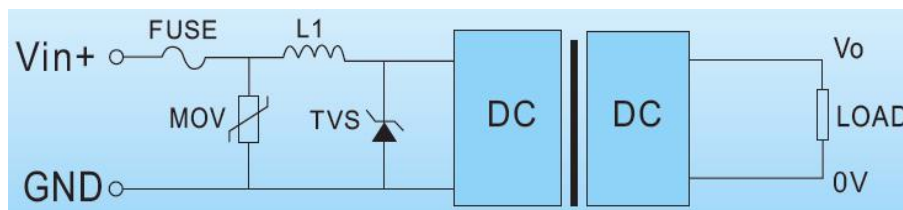

Diagram 3-8 instant over voltage and over current protection circuit

Note1: Ensure that the fuse can withstand the instantaneous inrush current when switch-on. More information please refer to datasheet.

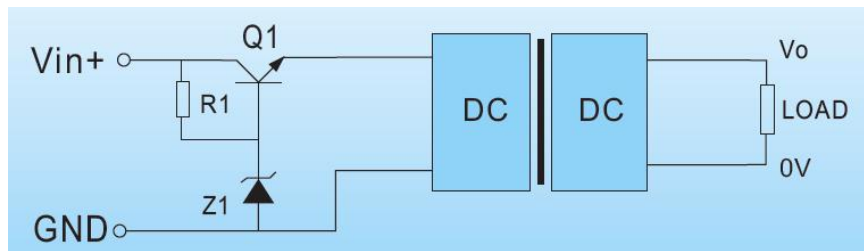

Diagram 3-9 Continuous over voltage protection circuit

Note2: The input value for over-voltage protection can not exceed the maximum one indicated in the datasheet.

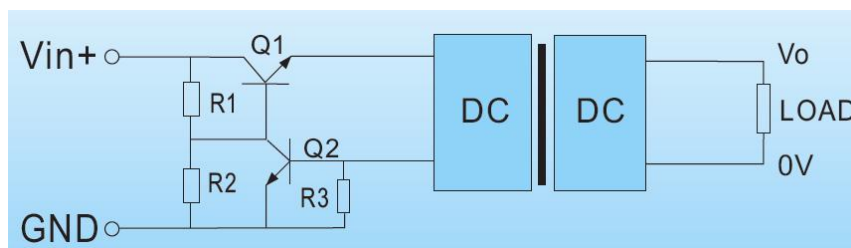

Diagram 3-10 Continuous over current protection circuit

It should detect the input current to achieve over-current protection and choose the appropriate current  $I_{limt}$  (set current value in the circuit for over-current protection). Grounding resistance R3 should be determined together by  $I_{limt}$  and the conduction voltage drop of transistor Q2 VBE. The formula is

$$R3 = \frac{0.7V}{I_{limt}}$$

Please notice the power consumption of resistor R3.

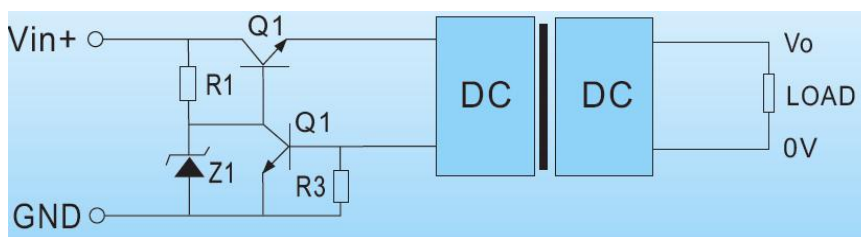

Diagram 3-11 Continuous over voltage and over current protection circuit

## F. Input and Output Filtering Circuit

Filters are usually connected at the input and output terminals of the converters to reduce ripple and noise in applications where are sensitive.

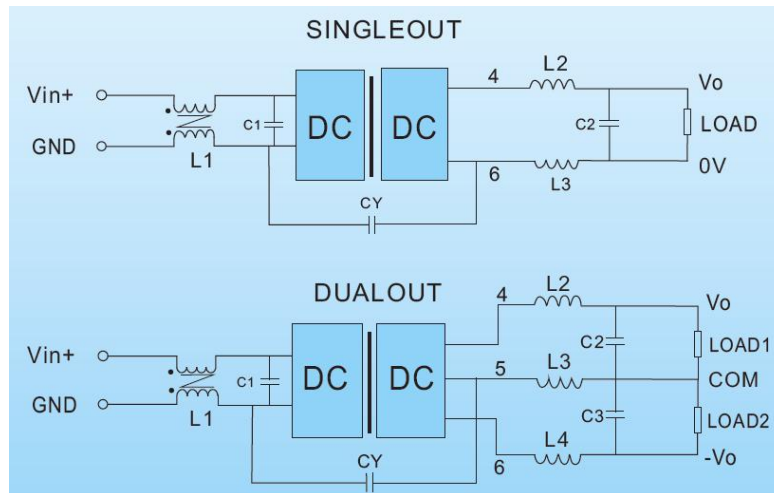

Diagram 3-12 Recommended circuit reducing ripple &amp; noise

Adding a capacitor at the input terminal can absorb the voltage spikes, save the energy and keep the voltage stable. Adding a capacitor at the output terminal can greatly reduce the output ripple, but it's likely to cause the failure of start-up due to too large capacitance or too low ESR. For applications requiring extremely low ripple, using a "LC" filter network or using converters with low ripple is an alternative.

C1: electrolytic capacitors, to reduce input ripple. Its value please refer to datasheet;

L2 / L3 / L4, C2 / C3: forming an LC filter network to reduce the output ripple. The capacitor is suggested to a ceramic capacitor or an electrolytic capacitor with low resistance, whose value is determined according to the actual ripple but cannot exceed the maximum capacitive load;

L1, CY: L1 is a common mode inductor to suppress common mode interference. Y1 is a Y capacitor offering 100-1000pF.

Note:

1) For MORNSUN's fixed input, unregulated output converters, it's recommended to connect conventional ceramic capacitors, not tantalum capacitor. Because the latter's ESR is very small and appears dummy output short when start-up, resulting in the input current impacts and damages the converter. Usually, about 10uF inrush current of tantalum capacitor has reached the limit of internal components.

2) for the components of the filter circuit, they are generally calculated according to the following formula and the frequency should be one of tenth of the converter's switching frequency.

$$f_c = \frac{1}{2\pi\sqrt{LC}}$$

The calculated value of filter may vary due to different application designs and load conditions, so the value must be adjusted in conjunction with the practical application.

When setting the value of the filter capacitor, it cannot exceed the maximum one of the capacitive load indicated in datasheet.

## **G. Electromagnetic Interference and Electromagnetic Compatibility**

### **a) Electromagnetic Interference (EMI)**

EMI is the pollution to the environment caused by electromagnetic radiation through the space, the signal line and the wire. It can not be completely eliminated, but can be reduced to a safe level. Certain effective ways to suppress EMI are generally:

- i) to shield EMI radiation: to select the products in metal shielded package or to add additional shield so as to reduce EMI radiation;
- ii) Reasonable grounding;
- iii) to select suitable filters or filter networks to reduce the transmission of EMI from the wire and the signal line;
- iv) to separately layout the converters and the small signal circuit, in order to effectively avoid the interference of the former to the latter.

### **b) Electromagnetic Compatibility (EMC)**

EMC is the ability of electronic equipment and power supply to work stably and reliably in a certain electromagnetic interference environment. It is also the ability of electronic equipment and power supply to limit their own electromagnetic interference and avoid interference with other electronic equipment.

Improving EMC is available from the following three aspects:

- i) to reduce the radiation of source of EMC interference;
- ii) to shield the transmission of EMC interference;
- iii) to improve anti-electromagnetic interference of the electronic equipment and power supply.

According to the way of transmission, EMC interference is divided into:

**i) Conduction interference.** It is the noise generated by the system into the DC input line or signal line. The frequency range is 150KHz-30MHz. Conduction interference has common mode and differential mode. LC network is often used to suppress the conducted interference.

**ii) Radiation interference.** It directly spreads in electromagnetic waves, plays a role of launch antenna and its frequency range is 30MHz-1GHz. Radiation interference can be suppressed by metal shielding.

### c) EMC Solution-recommended Circuit

As DC/DC converters are secondary power supplies, in order to pass EMS test, they usually connect external protection circuit at the DC/DC port or signal port, and add an inductance between TVS and varistor to discharge most of the interference energy. It can combine the TVS's lower clamping voltage and the varistor's larger flow, protecting the back-circuit. Here's the formula to calculate the inductance's value, where  $I_{pp} / 2$  mainly taking a 50% derating of the TVS into account:

$$L = \frac{(U_{c1} - U_{c2}) \times (20 - 8)}{I_{pp} / 2}$$

Diagram 3-13 EMC Solution-recommended Circuit

The circuit marked ② is used for EMI filtering and can be selected according to requirements.

Generally, DC/DC converters do not require EMS protection, but EMI peripheral circuits. For more information please refer to datasheet. MORNSUN's fixed input converters are secondary power supplies, only need EMI protection and EMS protection at the front-circuit.

## H. Capacitive Load

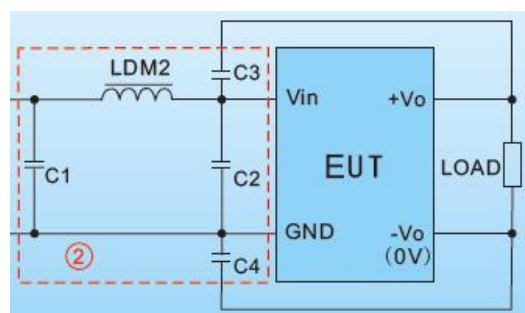
For general switching power supplies, it's recommended to connect electrolytic capacitors at the output terminal to meet the requirements for the maximum capacitive load. But it should be noted that too large capacitance or low ESR (equivalent series resistance) may cause the module to work unstable or bad start-up. For more details please refer to datasheet.

## III. FAQs

### A. Do MORNSUN's DC/DC converters support hot-plug?

"Hot-plug", simply refers to directly unplug or plug converters in the system without power-off.

The converters is not allowed to hot-plug during operation in that it will produce several times or even more of large current and voltage spikes of the converters, affecting internal components and damaging the converters in worse circumstances. Therefore, the converters don't support hot-plug.

### B. Can MORNSUN's DC/DC converters be used at no-load or light-load?

The converters can be used at no-load or light-load applications. However, under this condition, the conversion efficiency of the converters is relatively low and some indicators may not meet the requirements of datasheet. From the view of reliability, it's better to avoid these applications and the minimum output current of the converters should be no less than 10% of rated one. It's suggested to use the converters at 30-80% load or to choose the converters with lower power.

## C. Reasons cause failures of MORNSUN's DC/DC converters?

Reason 1: In actual application, the capacitive load exceeds the maximum value indicated in datasheet. Larger output capacitor requires larger starting current, which will cause the failure of the converters. To reduce the output capacitance at the output terminal or connect buffer circuit at it is a good choice to increase the capacity of the converters.

Reason 2: Limited to the maximum power provided by the intrinsically safe power supply, the starting power cannot meet the requirements of the converters (the converters require a large starting power at start-up). It is recommended to select the products with small starting current or connect a small resistance or NTC at the input terminal of the converters to reduce the start current.

Reason 3: the inductive load (usually motor coil) does not produce induced electromotive force when starting up. Only the coil's resistor  $r$  works in the entire loop, will resistance be very small (usually  $m\Omega \sim \Omega$  level). According to  $I = \frac{V}{r}$ , the current will be larger to exceed the over-current protection value of the converters, resulting in the protection of the converters, namely, failures of them. It is recommended to connect a small resistor in series at the output terminal for converters with low power, or select a power supply with larger power.

Note: R2 DC/DC converters have output short circuit protection and offer weaker peak current than their predecessors. So it needs to note whether the system has transient transmission function or transient start-up.

## D. Is it available to connect a tantalum capacitor at input and output terminals of MORNSUN's DC/DC converters?

On one hand, tantalum capacitor is relatively easy to breakdown for its short circuit characteristics and poor anti-surge ability. Once there is a relatively large instantaneous current or a high surge voltage at start-up, the tantalum capacitor will be over-voltage to breakdown and cause short circuit. On the other hand, tantalum capacitor's withstand



voltage will become low in high temperature environment. Therefore, in applications it's best not to connect any tantalum capacitor but ceramic capacitors or aluminum electrolytic capacitors at the input and output terminals of DC/DC converters.